

DATA PROJECTOR

MODEL

XG-C465X-L

XG-C435X-L

SETUP MANUAL

Setting up the Screen	2	SETUP MENU (Main Menu)	31
Screen Size and Projection Distance	3	ADVANCED SETUP MENU	31
Throw Distance	3	View Setting Detail List ([V]View All Setting)	32
Standard Zoom Lens	4	Set Items	32
Wide-zoom Lens (AN-C12MZ)	5	Save Settings and Quit ([S]Save & Quit)	33
Tele-zoom Lens (AN-C18MZ)	6	Quit without Saving Settings ([Q]Quit Unchanged) ..	33
Tele-zoom Lens (AN-C27MZ)	7	IP Address Setting ([1]IP Address)	34
Tele-zoom Lens (AN-C41MZ)	8	Subnet Mask Setting ([2]Subnet Mask)	34
Changing the Lens	9	Default Gateway Setting ([3]Default Gateway)	34
Connecting Pin Assignments	11	User Name Setting ([4]User Name)	34
RS-232C Specifications and Commands	13	Password Setting ([5>Password)	35
Computer control	13	RS-232C Baud Rate Setting	
Communication conditions	13	([6]RS-232C Baud Rate)	35
Basic format	13	Projector Name Setting ([7]Projector Name)	35
Commands	14	DHCP Client Setting ([8]DHCP Client)	35
Setting up the Projector Network Environment ...	18	Disconnecting All Connections	
Network settings on the computer	18	([D]Disconnect All)	36
1. Connecting the Projector to a Computer	19	Entering ADVANCED SETUP MENU	
2. Setting an IP Address for the Computer	20	([A]Advanced Setup)	36
3. Setting up a Network Connection for the Projector ...	22	Setting Auto Logout Time	
Controlling the Projector via LAN	24	(ADVANCED[1]Auto Logout Time)	36
Controlling the Projector Using Internet Explorer		Data Port Setting (ADVANCED[2]Data Port)	36
(Version 5.0 or later)	24	Carrying out Network Ping Test	
Confirming the Projector Status (Status)	25	(ADVANCED[5]Network Ping Test)	37
Controlling the Projector (Control)	25	Setting of Accept IP Address (ADVANCED[6]Accept	
Setting and Adjusting the Projector		IP Addr(1) – [8]Accept IP Addr(3))	37
(Settings & Adjustments)	26	Accepting All IP Addresses	
Setting the Security (Network – Security)	26	(ADVANCED[9]Accept All IP Addr)	37
Making General Settings for the Network		Setting of Search Port	
(Network - General)	27	(ADVANCED[0]Search Port)	38
Setting for Sending E-mail when an Error Occurs		Return to Default Settings	
(Mail – Originator Settings)	27	(ADVANCED[!]Restore Default Setting)	38
Setting Error Items and Destination Addresses		Return to Main Menu	
to which E-mail is to be Sent when an		(ADVANCED[Q]Return to Main Menu)	38
Error Occurs (Mail – Recipient Settings) ...	28	Resetting the Lamp Timer of the Projector	
Setting Error Items and the URL that are to be		via LAN	39
Displayed when an Error Occurs		Troubleshooting	41
(Service & Support – Access URL)	28	Wired Remote Control Terminal	
Setting up the Projector Using RS-232C or Telnet	29	Specifications	44
When Connecting Using RS-232C	29	Dimensions	45
When Connecting Using Telnet	30		

Setting up the Screen

For optimal image quality, position the projector perpendicular to the screen with the projector's feet flat and level. Doing so will eliminate the need for Keystone correction and provide the best image quality.

Note

- The projector lens should be centered in the middle of the screen. If the horizontal line passing through the lens center is not perpendicular to the screen, the image will be distorted, making viewing difficult.
- For an optimal image, position the screen so that it is not in direct sunlight or room light. Light falling directly on the screen washes out the colors, making viewing difficult. Close the curtains and dim the lights when setting up the screen in a sunny or bright room.

Standard Setup (Front Projection)

- Place the projector at the required distance from the screen according to the desired picture size.

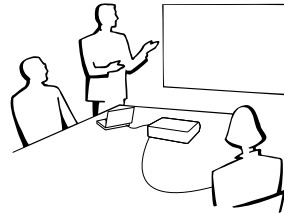

Example of standard setup

Side View

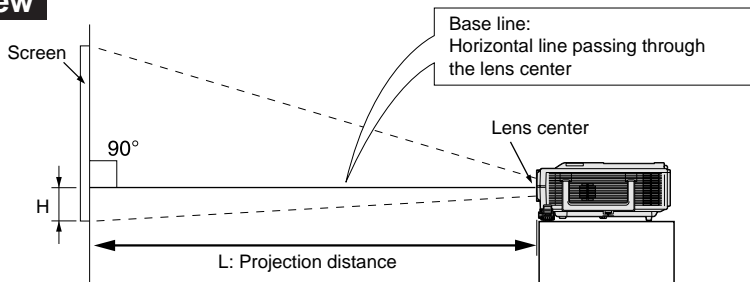

- The distance from the screen to the projector may vary depending on the size of the screen.
- The default setting can be used, when placing the projector in front of the screen. If the projected image is reversed, readjust the setting to "Front" in the "PRJ Mode" menu. (See page 52 of the projector's operation manual.)
- Place the projector so that an imaginary horizontal line that passes through the center of the lens is perpendicular to the screen.

Screen Size and Projection Distance

The projection screen size varies according to the distance from the lens of the projector to the screen. The optional lenses from Sharp are also available for specialized application. Please see your nearest Sharp Authorized Projector Dealer to details on all the lenses. (Refer to the lens operation manual when using a lens.)

Install the projector so that projected images are projected onto the screen at the optimum size by referring to the table. Use the values in the table as a reference when installing the projector.

Throw Distance

The graph below is for 100 inches (254 cm) screen with 4:3 normal mode.

Screen

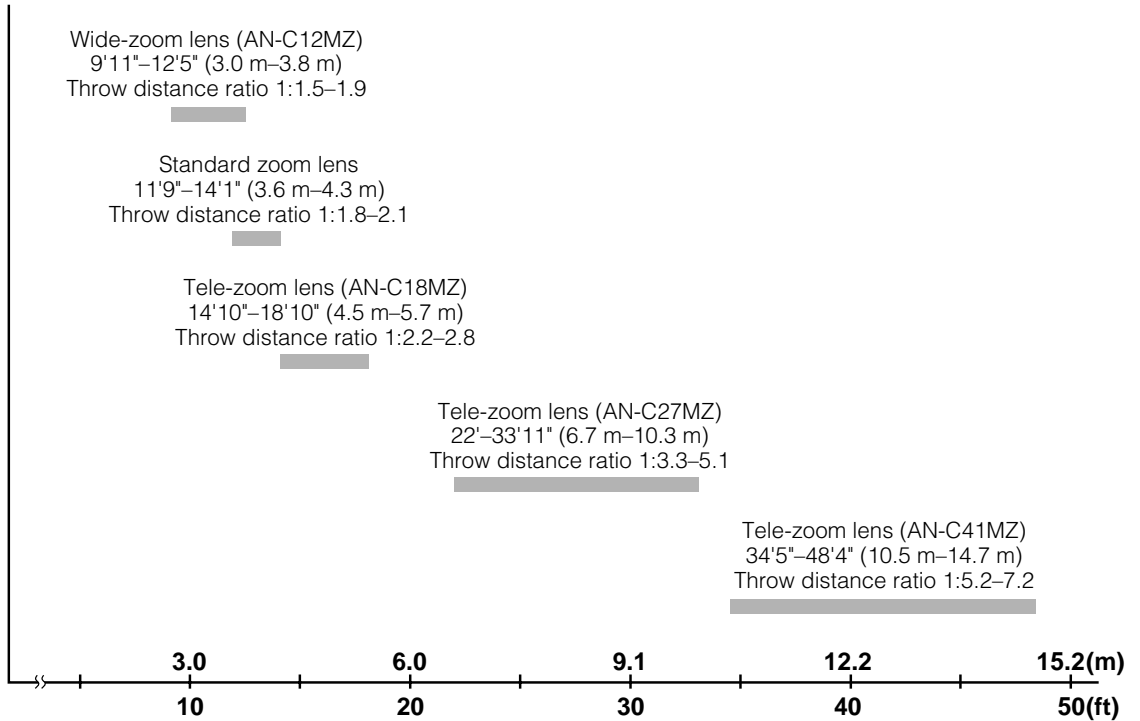

Screen Size and Projection Distance

Standard Zoom Lens

F1.7-F1.9, f=28.0-33.6 mm

NORMAL Mode (4:3)

Picture (Screen) size			Projection distance [L]		Distance from the lens center to the bottom of the image [H]
Diag. [χ]	Width	Height	Minimum [L1]	Maximum [L2]	
500" (1270 cm)	1016 cm (400")	762 cm (300")	17.9 m (58' 7")	21.4 m (70' 4")	-76 cm (-30")
300" (762 cm)	610 cm (240")	457 cm (180")	10.7 m (35' 2")	12.9 m (42' 2")	-46 cm (-18")
270" (686 cm)	549 cm (216")	411 cm (162")	9.6 m (31' 8")	11.6 m (38')	-41 cm (-16 13/64")
250" (635 cm)	508 cm (200")	381 cm (150")	8.9 m (29' 3")	10.7 m (35' 2")	-38 cm (-15")
200" (508 cm)	406 cm (160")	305 cm (120")	7.1 m (23' 5")	8.6 m (28' 1")	-30 cm (-12")
150" (381 cm)	305 cm (120")	229 cm (90")	5.4 m (17' 7")	6.4 m (21' 1")	-23 cm (-9")
100" (254 cm)	203 cm (80")	152 cm (60")	3.6 m (11' 9")	4.3 m (14' 1")	-15 cm (-6")
84" (213 cm)	171 cm (67")	128 cm (50")	3.0 m (9' 10")	3.6 m (11' 10")	-13 cm (-5 3/64")
80" (203 cm)	163 cm (64")	122 cm (48")	2.9 m (9' 4")	3.4 m (11' 3")	-12 cm (-4 51/64")
72" (183 cm)	146 cm (58")	110 cm (43")	2.6 m (8' 5")	3.1 m (10' 1")	-11 cm (-4 5/16")
60" (152 cm)	122 cm (48")	91 cm (36")	2.1 m (7')	2.6 m (8' 5")	-9 cm (-3 19/32")
40" (102 cm)	81 cm (32")	61 cm (24")	1.4 m (4' 8")	1.7 m (5' 7")	-6 cm (-2 13/32")

χ: Picture size (diag.) (in/cm)
 L: Projection distance(m/ft)
 L1: Minimum projection distance (m/ft)
 L2: Maximum projection distance (m/ft)
 H: Distance from the lens center to the bottom of the image (cm/in)

The formula for picture size and projection distance
[m/cm]
 $L1 (m) = 0.03571χ$
 $L2 (m) = 0.04286χ$
 $H (cm) = -0.1524χ$
[Feet/inches]
 $L1 (ft) = 0.03571χ / 0.3048$
 $L2 (ft) = 0.04286χ / 0.3048$
 $H (in) = -0.1524χ / 2.54$

STRETCH Mode (16:9)

Picture (Screen) size			Projection distance [L]		Distance from the lens center to the bottom of the image [H]	Adjustable range of image position [S]
Diag. [χ]	Width	Height	Minimum [L1]	Maximum [L2]		
450" (1143 cm)	996 cm (392")	560 cm (221")	17.5 m (57' 5")	21.0 m (68' 11")	19 cm (7 23/64")	±93 cm (±36 49/64")
300" (762 cm)	664 cm (261")	374 cm (147")	11.7 m (38' 3")	14.0 m (45' 11")	12 cm (4 29/32")	±62 cm (±24 33/64")
250" (635 cm)	553 cm (218")	311 cm (123")	9.7 m (31' 11")	11.7 m (38' 4")	10 cm (4 5/64")	±52 cm (±20 27/64")
225" (572 cm)	498 cm (196")	280 cm (110")	8.8 m (28' 9")	10.5 m (34' 6")	9 cm (3 43/64")	±47 cm (±18 25/64")
200" (508 cm)	443 cm (174")	249 cm (98")	7.8 m (25' 6")	9.3 m (30' 8")	8 cm (3 17/64")	±42 cm (±16 11/32")
150" (381 cm)	332 cm (131")	187 cm (74")	5.8 m (19' 2")	7.0 m (23')	6 cm (2 29/64")	±31 cm (±12 1/4")
133" (338 cm)	294 cm (116")	166 cm (65")	5.2 m (17')	6.2 m (20' 4")	6 cm (2 11/64")	±28 cm (±10 7/8")
106" (269 cm)	235 cm (92")	132 cm (52")	4.1 m (13' 6")	4.9 m (16' 3")	4 cm (1 47/64")	±22 cm (±8 21/32")
100" (254 cm)	221 cm (87")	125 cm (49")	3.9 m (12' 9")	4.7 m (15' 4")	4 cm (1 41/64")	±21 cm (±8 11/64")
92" (234 cm)	204 cm (80")	115 cm (45")	3.6 m (11' 9")	4.3 m (14' 1")	4 cm (1 1/2")	±19 cm (±7 33/64")
84" (213 cm)	186 cm (73")	105 cm (41")	3.3 m (10' 9")	3.9 m (12' 10")	3 cm (1 3/8")	±17 cm (±6 59/64")
80" (203 cm)	177 cm (70")	100 cm (39")	3.1 m (10' 3")	3.7 m (12' 3")	3 cm (1 5/16")	±17 cm (±6 17/32")
72" (183 cm)	159 cm (63")	90 cm (35")	2.8 m (9' 2")	3.4 m (11')	3 cm (1 11/64")	±15 cm (±5 57/64")
60" (152 cm)	133 cm (52")	75 cm (29")	2.3 m (7' 8")	2.8 m (9' 2")	2 cm (63/64")	±12 cm (±4 29/32")
40" (102 cm)	89 cm (35")	50 cm (20")	1.6 m (5' 1")	1.9 m (6' 2")	2 cm (21/32")	±8 cm (±3 17/64")

χ: Picture size (diag.) (in/cm)
 L: Projection distance(m/ft)
 L1: Minimum projection distance (m/ft)
 L2: Maximum projection distance (m/ft)
 H: Distance from the lens center to the bottom of the image (cm/in)
 S: Adjustable range of image position (cm/in)

The formula for picture size and projection distance
[m/cm]
 $L1 (m) = 0.0389χ$
 $L2 (m) = 0.04669χ$
 $H (cm) = 0.04151χ$
 $S (cm) = ±0.20754χ$
[Feet/inches]
 $L1 (ft) = 0.0389χ / 0.3048$
 $L2 (ft) = 0.04669χ / 0.3048$
 $H (in) = 0.04151χ / 2.54$
 $S (in) = ±0.20754χ / 2.54$



Note

- Allow a margin of error in the value in the diagrams above.
- When the distance from the lens center to the bottom of the image [H] is a negative number, this indicates that the bottom of the image is below the lens center.

Wide-zoom Lens (AN-C12MZ)

F2.2-F2.7, f=24.5-30.7 mm

NORMAL Mode (4:3)

Picture (Screen) size			Projection distance [L]		Distance from the lens center to the bottom of the image [H]	
Diag. [X]	Width	Height	Minimum [L1]	Maximum [L2]		
250" (635 cm)	508 cm (200")	381 cm (150")	7.5 m (24' 9")	9.5 m (31')	-38 cm (-15")	
200" (508 cm)	406 cm (160")	305 cm (120")	6.0 m (19' 10")	7.6 m (24' 10")	-30 cm (-12")	
150" (381 cm)	305 cm (120")	229 cm (90")	4.5 m (14' 10")	5.7 m (18' 7")	-23 cm (-9")	
100" (254 cm)	203 cm (80")	152 cm (60")	3.0 m (9' 11")	3.8 m (12' 5")	-15 cm (-6")	
84" (213 cm)	171 cm (67")	128 cm (50")	2.5 m (8' 4")	3.2 m (10' 5")	-13 cm (-5 3/64")	
80" (203 cm)	163 cm (64")	122 cm (48")	2.4 m (7' 11")	3.0 m (9' 11")	-12 cm (-4 51/64")	
72" (183 cm)	146 cm (58")	110 cm (43")	2.2 m (7' 2")	2.7 m (8' 11")	-11 cm (-4 5/16")	
60" (152 cm)	122 cm (48")	91 cm (36")	1.8 m (5' 11")	2.3 m (7' 5")	-9 cm (-3 19/32")	
40" (102 cm)	81 cm (32")	61 cm (24")	1.2 m (4')	1.5 m (5')	-6 cm (-2 13/32")	

X: Picture size (diag.) (in/cm)
 L: Projection distance(m/ft)
 L1: Minimum projection distance (m/ft)
 L2: Maximum projection distance (m/ft)
 H: Distance from the lens center to the bottom of the image (cm/in)

The formula for picture size and projection distance
[m/cm]
 L1 (m) = 0.03019X / 0.3048
 L2 (m) = 0.03783X / 0.3048
 H (cm) = -0.1524X
[Feet/inches]
 L1 (ft) = 0.03019X / 0.3048
 L2 (ft) = 0.03783X / 0.3048
 H (in) = -0.1524X / 2.54

STRETCH Mode (16:9)

Picture (Screen) size			Projection distance [L]		Distance from the lens center to the bottom of the image [H]		Adjustable range of image position [S]
Diag. [X]	Width	Height	Minimum [L1]	Maximum [L2]			
225" (572 cm)	498 cm (196")	280 cm (110")	7.4 m (24' 3")	9.3 m (30' 5")	9 cm (3 43/64")	±47 cm (±18 25/64")	
200" (508 cm)	443 cm (174")	249 cm (98")	6.6 m (21' 7")	8.2 m (27')	8 cm (3 17/64")	±42 cm (±16 11/32")	
150" (381 cm)	332 cm (131")	187 cm (74")	4.9 m (16' 2")	6.2 m (20' 3")	6 cm (2 29/64")	±31 cm (±12 1/4")	
133" (338 cm)	294 cm (116")	166 cm (65")	4.4 m (14' 4")	5.5 m (18')	6 cm (2 11/64")	±28 cm (±10 7/8")	
106" (269 cm)	235 cm (92")	132 cm (52")	3.5 m (11' 5")	4.4 m (14' 4")	4 cm (1 47/64")	±22 cm (±8 21/32")	
100" (254 cm)	221 cm (87")	125 cm (49")	3.3 m (10' 9")	4.1 m (13' 6")	4 cm (1 41/64")	±21 cm (±8 11/64")	
92" (234 cm)	204 cm (80")	115 cm (45")	3.0 m (9' 11")	3.8 m (12' 5")	4 cm (1 1/2")	±19 cm (±7 33/64")	
84" (213 cm)	186 cm (73")	105 cm (41")	2.8 m (9' 1")	3.5 m (11' 4")	3 cm (1 3/8")	±17 cm (±6 55/64")	
80" (203 cm)	177 cm (70")	100 cm (39")	2.6 m (8' 8")	3.3 m (10' 10")	3 cm (1 5/16")	±17 cm (±6 17/32")	
72" (183 cm)	159 cm (63")	90 cm (35")	2.4 m (7' 9")	3.0 m (9' 9")	3 cm (1 11/64")	±15 cm (±5 57/64")	
60" (152 cm)	133 cm (52")	75 cm (29")	2.0 m (6' 6")	2.5 m (8' 1")	2 cm (63/64")	±12 cm (±4 29/32")	
40" (102 cm)	89 cm (35")	50 cm (20")	1.3 m (4' 4")	1.6 m (5' 5")	2 cm (21/32")	±8 cm (±3 17/64")	

X: Picture size (diag.) (in/cm)
 L: Projection distance(m/ft)
 L1: Minimum projection distance (m/ft)
 L2: Maximum projection distance (m/ft)
 H: Distance from the lens center to the bottom of the image (cm/in)
 S: Adjustable range of image position (cm/in)

The formula for picture size and projection distance
[m/cm]
 L1 (m) = 0.03289X / 0.3048
 L2 (m) = 0.04121X / 0.3048
 H (cm) = 0.04151X
 S (cm) = ±0.20754X
[Feet/inches]
 L1 (ft) = 0.03289X / 0.3048
 L2 (ft) = 0.04121X / 0.3048
 H (in) = 0.04151X / 2.54
 S (in) = ±0.20754X / 2.54



- Allow a margin of error in the value in the diagrams above.
- When the distance from the lens center to the bottom of the image [H] is a negative number, this indicates that the bottom of the image is below the lens center.

Screen Size and Projection Distance

Tele-zoom Lens (AN-C18MZ)

F1.7-F2.2, f=36.5-46.3 mm

NORMAL Mode (4:3)

Picture (Screen) size			Projection distance [L]		Distance from the lens center to the bottom of the image [H]
Diag. [X]	Width	Height	Minimum [L1]	Maximum [L2]	
250" (635 cm)	508 cm (200")	381 cm (150")	11.3 m (37' 2")	14.4 m (47' 1")	-38 cm (-15")
200" (508 cm)	406 cm (160")	305 cm (120")	9.1 m (29' 9")	11.5 m (37' 8")	-30 cm (-12")
150" (381 cm)	305 cm (120")	229 cm (90")	6.8 m (22' 3")	8.6 m (28' 3")	-23 cm (-9")
100" (254 cm)	203 cm (80")	152 cm (60")	4.5 m (14' 10")	5.7 m (18' 10")	-15 cm (-6")
84" (213 cm)	171 cm (67")	128 cm (50")	3.8 m (12' 6")	4.8 m (15' 10")	-13 cm (-5 3/64")
80" (203 cm)	163 cm (64")	122 cm (48")	3.6 m (11' 11")	4.6 m (15' 1")	-12 cm (-4 51/64")
72" (183 cm)	146 cm (58")	110 cm (43")	3.3 m (10' 8")	4.1 m (13' 7")	-11 cm (-4 5/16")
60" (152 cm)	122 cm (48")	91 cm (36")	2.7 m (8' 11")	3.4 m (11' 4")	-9 cm (-3 19/32")
40" (102 cm)	81 cm (32")	61 cm (24")	1.8 m (5' 11")	2.3 m (7' 6")	-6 cm (-2 13/32")

X: Picture size (diag.) (in/cm)
 L: Projection distance(m/ft)
 L1: Minimum projection distance (m/ft)
 L2: Maximum projection distance (m/ft)
 H: Distance from the lens center to the bottom of the image (cm/in)

The formula for picture size and projection distance

[m/cm]

L1 (m) = 0.04529X

L2 (m) = 0.05745X

H1 (cm) = -0.1524X

[Feet/inches]

L1 (ft) = 0.04529X / 0.3048

L2 (ft) = 0.05745X / 0.3048

H (in) = -0.1524X / 2.54

STRETCH Mode (16:9)

Picture (Screen) size			Projection distance [L]		Distance from the lens center to the bottom of the image [H]	Adjustable range of image position [S]
Diag. [X]	Width	Height	Minimum [L1]	Maximum [L2]		
225" (572 cm)	498 cm (196")	280 cm (110")	11.1 m (36' 5")	14.1 m (46' 2")	9 cm (3 43/64")	±47 cm (±18 25/64")
200" (508 cm)	443 cm (174")	249 cm (98")	9.9 m (32' 5")	12.5 m (41' 1")	8 cm (3 17/64")	±42 cm (±16 11/32")
150" (381 cm)	332 cm (131")	187 cm (74")	7.4 m (24' 3")	9.4 m (30' 10")	6 cm (2 29/64")	±31 cm (±12 1/4")
133" (338 cm)	294 cm (116")	166 cm (65")	6.6 m (21' 6")	8.3 m (27' 4")	6 cm (2 11/64")	±28 cm (±10 7/8")
106" (269 cm)	235 cm (92")	132 cm (52")	5.2 m (17' 2")	6.6 m (21' 9")	4 cm (1 47/64")	±22 cm (±8 21/32")
100" (254 cm)	221 cm (87")	125 cm (49")	4.9 m (16' 2")	6.3 m (20' 6")	4 cm (1 41/64")	±21 cm (±8 11/64")
92" (234 cm)	204 cm (80")	115 cm (45")	4.5 m (14' 11")	5.8 m (18' 11")	4 cm (1 1/2")	±19 cm (±7 33/64")
84" (213 cm)	186 cm (73")	105 cm (41")	4.1 m (13' 7")	5.3 m (17' 3")	3 cm (1 3/8")	±17 cm (±6 55/64")
80" (203 cm)	177 cm (70")	100 cm (39")	3.9 m (12' 11")	5.0 m (16' 5")	3 cm (1 5/16")	±17 cm (±6 17/32")
72" (183 cm)	159 cm (63")	90 cm (35")	3.6 m (11' 8")	4.5 m (14' 9")	3 cm (1 11/64")	±15 cm (±5 57/64")
60" (152 cm)	133 cm (52")	75 cm (29")	3.0 m (9' 9")	3.8 m (12' 4")	2 cm (63/64")	±12 cm (±4 29/32")
40" (102 cm)	89 cm (35")	50 cm (20")	2.0 m (6' 6")	2.5 m (8' 3")	2 cm (21/32")	±8 cm (±3 17/64")

X: Picture size (diag.) (in/cm)
 L: Projection distance(m/ft)
 L1: Minimum projection distance (m/ft)
 L2: Maximum projection distance (m/ft)
 H: Distance from the lens center to the bottom of the image (cm/in)
 S: Adjustable range of image position (cm/in)

The formula for picture size and projection distance

[m/cm]

L1 (m) = 0.04934X

L2 (m) = 0.06259X

H (cm) = 0.04151X

S (cm) = ±0.20754X

[Feet/inches]

L1 (ft) = 0.04934X / 0.3048

L2 (ft) = 0.06259X / 0.3048

H1 (in) = 0.04151X / 2.54

S (in) = ±0.20754X / 2.54



Note

- Allow a margin of error in the value in the diagrams above.
- When the distance from the lens center to the bottom of the image [H] is a negative number, this indicates that the bottom of the image is below the lens center.

Tele-zoom Lens (AN-C27MZ)

F2.0-F2.8, f=53.8-82.9 mm

NORMAL Mode (4:3)

Picture (Screen) size			Projection distance [L]		Distance from the lens center to the bottom of the image [H]	
Diag. [X]	Width	Height	Minimum [L1]	Maximum [L2]		
250" (635 cm)	508 cm (200")	381 cm (150")	16.8 m (55')	25.9 m (84' 11")	-38 cm (-15")	
200" (508 cm)	406 cm (160")	305 cm (120")	13.4 m (44')	20.7 m (67' 11")	-30 cm (-12")	
150" (381 cm)	305 cm (120")	229 cm (90")	10.1 m (33')	15.5 m (50' 11")	-23 cm (-9")	
100" (254 cm)	203 cm (80")	152 cm (60")	6.7 m (22')	10.3 m (33' 11")	-15 cm (-6")	
84" (213 cm)	171 cm (67")	128 cm (50")	5.6 m (18' 6")	8.7 m (28' 6")	-13 cm (-5 3/64")	
80" (203 cm)	163 cm (64")	122 cm (48")	5.4 m (17' 7")	8.3 m (27' 2")	-12 cm (-4 51/64")	
72" (183 cm)	146 cm (58")	110 cm (43")	4.8 m (15' 10")	7.5 m (24' 5")	-11 cm (-4 5/16")	
60" (152 cm)	122 cm (48")	91 cm (36")	4.0 m (13' 3")	6.2 m (20' 4")	-9 cm (-3 19/32")	
40" (102 cm)	81 cm (32")	61 cm (24")	2.7 m (8' 10")	4.1 m (13' 7")	-6 cm (-2 13/32")	

X: Picture size (diag.) (in/cm)
 L: Projection distance(m/ft)
 L1: Minimum projection distance (m/ft)
 L2: Maximum projection distance (m/ft)
 H: Distance from the lens center to the bottom of the image (cm/in)

The formula for picture size and projection distance

[m/cm]
 L1 (m) = 0.0671X
 L2 (m) = 0.10348X
 H (cm) = -0.1524X
[Feet/inches]
 L1 (ft) = 0.0671X / 0.3048
 L2 (ft) = 0.10348X / 0.3048
 H (in) = -0.1524X / 2.54

STRETCH Mode (16:9)

Picture (Screen) size			Projection distance [L]		Distance from the lens center to the bottom of the image [H]		Adjustable range of image position [S]
Diag. [X]	Width	Height	Minimum [L1]	Maximum [L2]			
225" (572 cm)	498 cm (196")	280 cm (110")	16.4 m (54')	25.4 m (83' 3")	9 cm (3 43/64")	±47 cm (±18 25/64")	
200" (508 cm)	443 cm (174")	249 cm (98")	14.6 m (48')	22.5 m (74')	8 cm (3 17/64")	±42 cm (±16 11/32")	
150" (381 cm)	332 cm (131")	187 cm (74")	11.0 m (36')	16.9 m (55' 6")	6 cm (2 29/64")	±31 cm (±12 1/4")	
133" (338 cm)	294 cm (116")	166 cm (65")	9.7 m (31' 11")	15.0 m (49' 2")	6 cm (2 11/64")	±28 cm (±10 7/8")	
106" (269 cm)	235 cm (92")	132 cm (52")	7.7 m (25' 5")	12.0 m (39' 2")	4 cm (1 47/64")	±22 cm (±8 21/32")	
100" (254 cm)	221 cm (87")	125 cm (49")	7.3 m (24')	11.3 m (37')	4 cm (1 41/64")	±21 cm (±8 11/64")	
92" (234 cm)	204 cm (80")	115 cm (45")	6.7 m (22' 1")	10.4 m (34')	4 cm (1 1/2")	±19 cm (±7 33/64")	
84" (213 cm)	186 cm (73")	105 cm (41")	6.1 m (20' 2")	9.5 m (31' 1")	3 cm (1 3/8")	±17 cm (±6 55/64")	
80" (203 cm)	177 cm (70")	100 cm (39")	5.8 m (19' 2")	9.0 m (29' 7")	3 cm (1 5/16")	±17 cm (±6 17/32")	
72" (183 cm)	159 cm (63")	90 cm (35")	5.3 m (17' 3")	8.1 m (26' 8")	3 cm (1 11/64")	±15 cm (±5 57/64")	
60" (152 cm)	133 cm (52")	75 cm (29")	4.4 m (14' 5")	6.8 m (22' 2")	2 cm (63/64")	±12 cm (±4 29/32")	
40" (102 cm)	89 cm (35")	50 cm (20")	2.9 m (9' 7")	4.5 m (14' 10")	2 cm (21/32")	±8 cm (±3 17/64")	

X: Picture size (diag.) (in/cm)
 L: Projection distance(m/ft)
 L1: Minimum projection distance (m/ft)
 L2: Maximum projection distance (m/ft)
 H: Distance from the lens center to the bottom of the image (cm/in)
 S: Adjustable range of image position (cm/in)

The formula for picture size and projection distance

[m/cm]
 L1 (m) = 0.0731X
 L2 (m) = 0.11274X
 H (cm) = 0.04151X
 S (cm) = ±0.20754X
[Feet/inches]
 L1 (ft) = 0.0731X / 0.3048
 L2 (ft) = 0.11274X / 0.3048
 H (in) = 0.04151X / 2.54
 S (in) = ±0.20754X / 2.54



Note

- Allow a margin of error in the value in the diagrams above.
- When the distance from the lens center to the bottom of the image [H] is a negative number, this indicates that the bottom of the image is below the lens center.

Screen Size and Projection Distance

Tele-zoom Lens (AN-C41MZ)

F2.1-F2.8, f=83.5-117.2 mm

NORMAL Mode (4:3)

Picture (Screen) size			Projection distance [L]		Distance from the lens center to the bottom of the image [H]
Diag. [X]	Width	Height	Minimum [L1]	Maximum [L2]	
250" (635 cm)	508 cm (200")	381 cm (150")	26.2 m (86')	36.8 m (120' 9")	-38 cm (-15")
200" (508 cm)	406 cm (160")	305 cm (120")	21.0 m (68' 10")	29.5 m (96' 7")	-30 cm (-12")
150" (381 cm)	305 cm (120")	229 cm (90")	15.7 m (51' 7")	22.1 m (72' 6")	-23 cm (-9")
100" (254 cm)	203 cm (80")	152 cm (60")	10.5 m (34' 5")	14.7 m (48' 4")	-15 cm (-6")
84" (213 cm)	171 cm (67")	128 cm (50")	8.8 m (28' 11")	12.4 m (40' 7")	-13 cm (-5 3/64")
80" (203 cm)	163 cm (64")	122 cm (48")	8.4 m (27' 6")	11.8 m (38' 8")	-12 cm (-4 51/64")
72" (183 cm)	146 cm (58")	110 cm (43")	7.5 m (24' 9")	10.6 m (34' 9")	-11 cm (-4 5/16")
60" (152 cm)	122 cm (48")	91 cm (36")	6.3 m (20' 8")	8.8 m (29')	-9 cm (-3 19/32")
40" (102 cm)	81 cm (32")	61 cm (24")	4.2 m (13' 9")	5.9 m (19' 4")	-6 cm (-2 13/32")

X: Picture size (diag.) (in/cm)
 L: Projection distance(m/ft)
 L1: Minimum projection distance (m/ft)
 L2: Maximum projection distance (m/ft)
 H: Distance from the lens center to the bottom of the image (cm/in)

The formula for picture size and projection distance

[m/cm]
 L1 (m) = 0.10484X
 L2 (m) = 0.14725X
 H (cm) = -0.1524X
[Feet/inches]
 L1 (ft) = 0.10484X / 0.3048
 L2 (ft) = 0.14725X / 0.3048
 H (in) = -0.1524X / 2.54

STRETCH Mode (16:9)

Picture (Screen) size			Projection distance [L]		Distance from the lens center to the bottom of the image [H]	Adjustable range of image position [S]
Diag. [X]	Width	Height	Minimum [L1]	Maximum [L2]		
225" (572 cm)	498 cm (196")	280 cm (110")	25.7 m (84' 4")	36.1 m (118' 5")	9 cm (3 43/64")	±47 cm (±18 25/64")
200" (508 cm)	443 cm (174")	249 cm (98")	22.8 m (74' 11")	32.1 m (105' 3")	8 cm (3 17/64")	±42 cm (±16 11/32")
150" (381 cm)	332 cm (131")	187 cm (74")	17.1 m (56' 3")	24.1 m (78' 11")	6 cm (2 29/64")	±31 cm (±12 1/4")
133" (338 cm)	294 cm (116")	166 cm (65")	15.2 m (49' 10")	21.3 m (70')	6 cm (2 11/64")	±28 cm (±10 7/8")
106" (269 cm)	235 cm (92")	132 cm (52")	12.1 m (39' 9")	17.0 m (55' 9")	4 cm (1 47/64")	±22 cm (±8 21/32")
100" (254 cm)	221 cm (87")	125 cm (49")	11.4 m (37' 6")	16.0 m (52' 8")	4 cm (1 41/64")	±21 cm (±8 11/64")
92" (234 cm)	204 cm (80")	115 cm (45")	10.5 m (34' 6")	14.8 m (48' 5")	4 cm (1 1/2")	±19 cm (±7 33/64")
84" (213 cm)	186 cm (73")	105 cm (41")	9.6 m (31' 6")	13.5 m (44' 3")	3 cm (1 3/8")	±17 cm (±6 55/64")
80" (203 cm)	177 cm (70")	100 cm (39")	9.1 m (30')	12.8 m (42' 1")	3 cm (1 5/16")	±17 cm (±6 17/32")
72" (183 cm)	159 cm (63")	90 cm (35")	8.2 m (27')	11.6 m (37' 11")	3 cm (1 11/64")	±15 cm (±5 57/64")
60" (152 cm)	133 cm (52")	75 cm (29")	6.9 m (22' 6")	9.6 m (31' 7")	2 cm (63/64")	±12 cm (±4 29/32")
40" (102 cm)	89 cm (35")	50 cm (20")	4.6 m (15')	6.4 m (21' 1")	2 cm (21/32")	±8 cm (±3 17/64")

X: Picture size (diag.) (in/cm)
 L: Projection distance(m/ft)
 L1: Minimum projection distance (m/ft)
 L2: Maximum projection distance (m/ft)
 H: Distance from the lens center to the bottom of the image (cm/in)
 S: Adjustable range of image position (cm/in)

The formula for picture size and projection distance

[m/cm]
 L1 (m) = 0.11422X
 L2 (m) = 0.16042X
 H (cm) = 0.04151X
 S (cm) = ±0.20754X
[Feet/inches]
 L1 (ft) = 0.11422X / 0.3048
 L2 (ft) = 0.16042X / 0.3048
 H (in) = 0.04151X / 2.54
 S (in) = ±0.20754X / 2.54



Note

- Allow a margin of error in the value in the diagrams above.
- When the distance from the lens center to the bottom of the image [H] is a negative number, this indicates that the bottom of the image is below the lens center.

Changing the Lens

Info

- Before changing the lens, turn off the power of the projector and remove the power cord from the wall outlet.
- Do not attempt to change the lens while the projector is mounted on the ceiling.

1 Remove the lens housing cover by using the supplied lens housing cover removal tool to push down on the groove on the lens housing cover.

- Hold down the lens housing cover with your hand to prevent it from flying out.

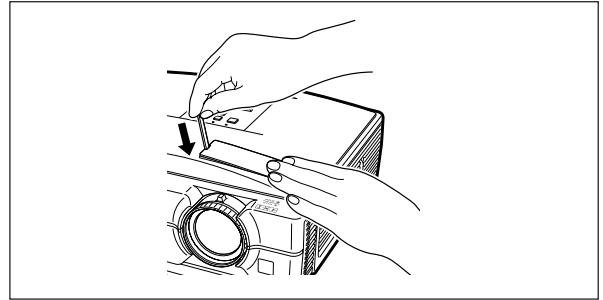

2 Slide the lens fastener catch tab in the direction of “UNLOCK” while holding the lens to prevent it from falling out.

- Slide the lens fastener catch tab until the window located beside “LOCK” comes to the top. Look inside the window to make sure that the two grooves on the lens fastener ring are facing up.

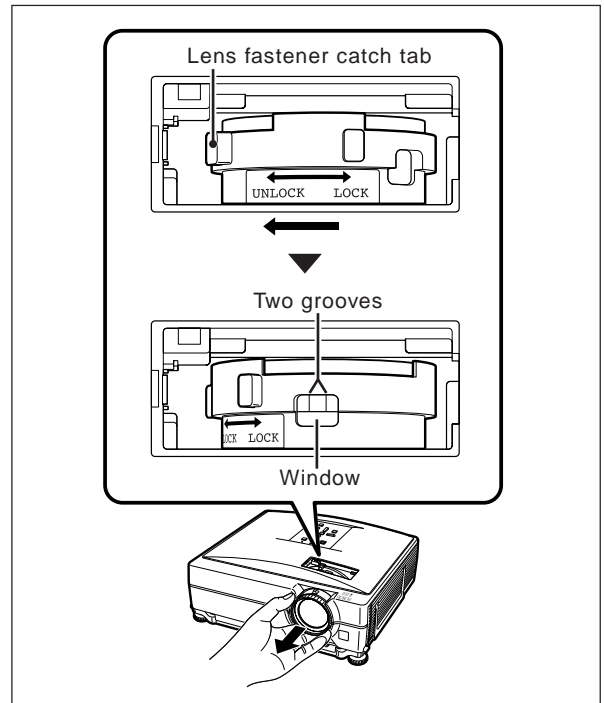

3 Remove the lens by pulling it straight out.

4 Remove the protection cap from the back of the new lens.

Changing the Lens

5 Insert the lens into the projector.

- As you insert the lens, look inside the window to make sure that the pin is inserted into the hole of the lens mount.

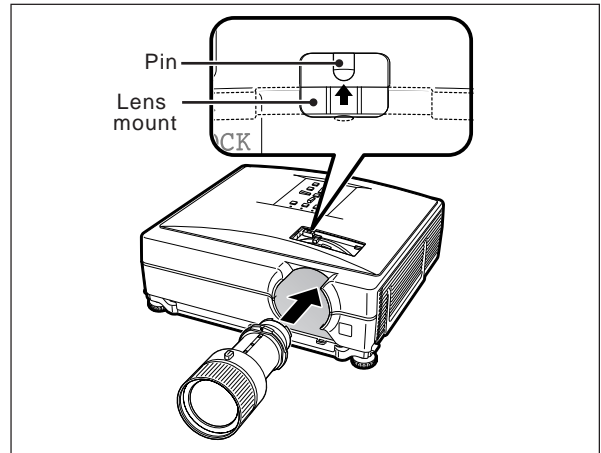

6 Slide the lens fastener catch tab in the direction of "LOCK" until it stops.

- Be careful not to rotate the lens fastener ring too tight, as the lens fastener ring will be difficult to loosen the next time the lens is changed.

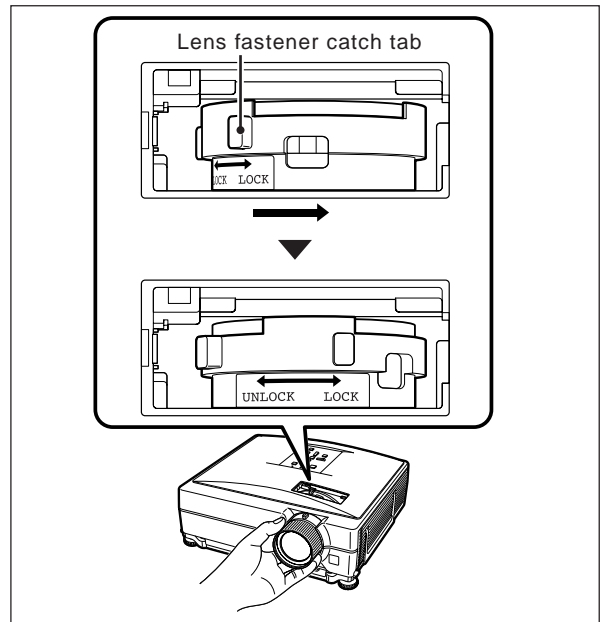

7 Replace the lens housing cover.

- If the lens housing cover is not secured to the projector, you will not be able to turn the power on.

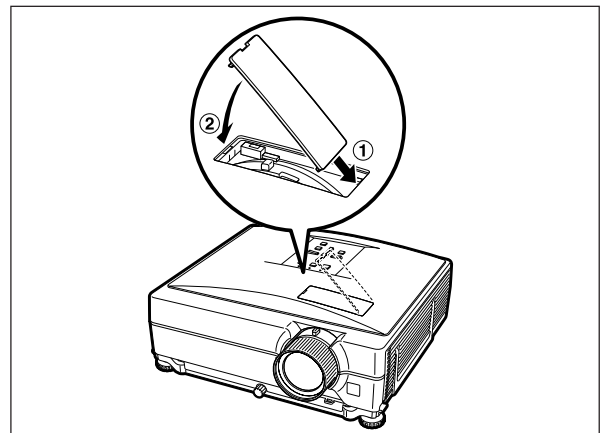

Connecting Pin Assignments

COMPUTER-RGB/COMPONENT INPUT 1, 2 and COMPUTER-RGB/COMPONENT OUTPUT Terminals: mini D-sub 15-pin female connector

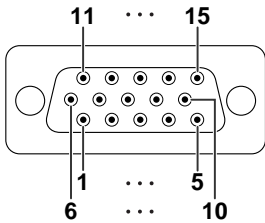

COMPUTER-RGB Input/Output

1. Video input (red)
2. Video input (green/sync on green)
3. Video input (blue)
4. Not connected
5. Not connected
6. Earth (red)
7. Earth (green/sync on green)
8. Earth (blue)
9. Not connected
10. GND
11. Not connected
12. Bi-directional data
13. Horizontal sync signal: TTL level
14. Vertical sync signal: TTL level
15. Data clock

Component Input/Output

1. P_R (C_R)
2. Y
3. P_B (C_B)
4. Not connected
5. Not connected
6. Earth (P_R)
7. Earth (Y)
8. Earth (P_B)
9. Not connected
10. Not connected
11. Not connected
12. Not connected
13. Not connected
14. Not connected
15. Not connected

RS-232C Terminal: mini DIN 9-pin female connector

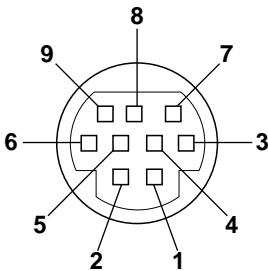

Pin No.	Signal	Name	I/O	Reference
1				Not connected
2	RD	Receive Data	Input	Connected to internal circuit
3	SD	Send Data	Output	Connected to internal circuit
4				Not connected
5	SG	Signal Ground		Connected to internal circuit
6				Not connected
7	RS	Request to Send		Connected to CS in internal circuit
8	CS	Clear to Send		Connected to RS in internal circuit
9				Not connected

RS-232C Terminal: D-sub 9-pin male connector of the DIN-D-sub RS-232C adaptor

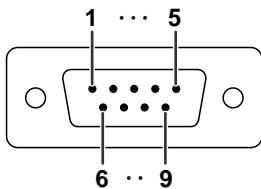

Pin No.	Signal	Name	I/O	Reference
1				Not connected
2	RD	Receive Data	Input	Connected to internal circuit
3	SD	Send Data	Output	Connected to internal circuit
4				Not connected
5	SG	Signal Ground		Connected to internal circuit
6				Not connected
7	RS	Request to Send		Connected to CS in internal circuit
8	CS	Clear to Send		Connected to RS in internal circuit
9				Not connected

RS-232C Cable recommended connection: D-sub 9-pin female connector

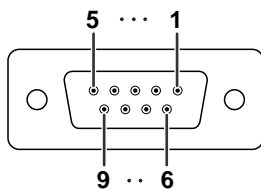

Pin No.	Signal	Pin No.	Signal
1	CD	1	CD
2	RD	2	RD
3	SD	3	SD
4	ER	4	ER
5	SG	5	SG
6	DR	6	DR
7	RS	7	RS
8	CS	8	CS
9	CI	9	CI



Note

- Depending on the controlling device used, it may be necessary to connect Pin 4 and Pin 6 on the controlling device (e.g. computer).



LAN Terminal : LAN (RJ-45)

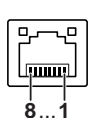

Pin No.	Signal	Pin No.	Signal
1	TX+	5	
2	TX-	6	RX-
3	RX+	7	
4		8	

Connecting Pin Assignments

DVI-D Terminal: 24 pin connector

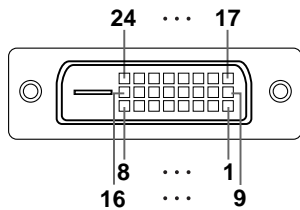

Pin No.	Signal	Pin No.	Signal
1	T.M.D.S. Data 2-	13	Not connected
2	T.M.D.S. Data 2+	14	+5 V Power
3	T.M.D.S. Data 2 Shield	15	Ground
4	Not connected	16	Hot Plug Detect
5	Not connected	17	T.M.D.S. Data 0-
6	DDC Clock	18	T.M.D.S. Data 0+
7	DDC Data	19	T.M.D.S. Data 0 Shield
8	Not connected	20	Not connected
9	T.M.D.S. Data 1-	21	Not connected
10	T.M.D.S. Data 1+	22	T.M.D.S. Clock Shield
11	T.M.D.S. Data 1 Shield	23	T.M.D.S. Clock+
12	Not connected	24	T.M.D.S. Clock-

RS-232C Specifications and Commands

Computer control

A computer can be used to control the projector by connecting an RS-232C serial control cable (cross type, commercially available) to the projector. (See page 27 of the projector's operation manual for connection.)

Communication conditions

Set the serial port settings of the computer to match that of the table.

Signal format: Conforms to RS-232C standard.

Parity bit: None

Baud rate*: 9,600 bps / 38,400 bps / 115,200 bps

Stop bit: 1 bit

Data length: 8 bits

Flow control: None

*Set the projector's baud rate to the same rate as used by the computer.

Basic format

Commands from the computer are sent in the following order: command, parameter, and return code. After the projector processes the command from the computer, it sends a response code to the computer.

Command format

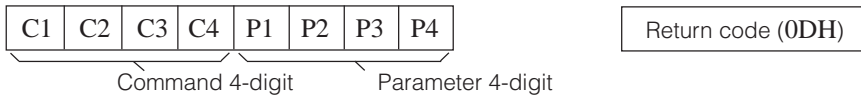

Response code format

Normal response

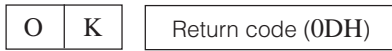

Problem response (communication error or incorrect command)



Info

- When controlling the projector using RS-232C commands from a computer, wait for at least 40 seconds after the power has been turned on, and then transmit the commands.
- After sending an input selection or picture adjustment command and then receiving an "OK" response code, the projector may take some time to process the command. If a second command is sent while the projector is still processing the first command, you may receive an "ERR" response code. If this happens, try resending the second command.
- When more than one code is being sent, send each command only after the response code for the previous command from the projector is verified.
- "POWR????", "TABN ___ 1", "TLPS ___ 1", "TPOW ___ 1", "TLPN ___ 1", "TLTT ___ 1", "TLTM ___ 1", "TLTL ___ 1", "TNAM ___ 1", "MNRD ___ 1", "PJNO ___ 1"
 - When the projector receives the special commands shown above:
 - * The on-screen display will not disappear.
 - * The "Auto Power Off" timer will not be reset.
 - The special commands are available for applications that require continuous polling.

Note

- If an underbar (_) appears in the parameter column, enter a space.
- If an asterisk (*) appears in the parameter column, enter a value in the range indicated in brackets under Control Contents.

PJLink™ Compliant:

This product conforms with the PJLink standard Class 1 and all Class 1 commands are implemented.

This product confirms with the PJLink standard specification version 1.00.

For additional information, visit "<http://pjlink.jbmia.or.jp/english/>".

RS-232C Specifications and Commands

Commands

Example: When turning on the projector, make the following setting.

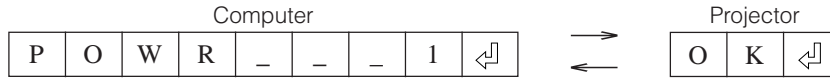

CONTROL CONTENTS			COMMAND	PARAMETER	RETURN	
					Power ON	Standby mode (or 40-second startup time)
Power	On		P O W R	- - - - 1	OK or ERR	OK
	Off		P O W R	- - - - 0	OK	OK or ERR
	Status		P O W R	? ? ? ? 1		0
Projector Condition			T A B N	- - - - 1	0: Normal 1: Temp High 8: Lamp Life 5% or less 16: Lamp Burn-out 32: Lamp Ignition Failure	0: Normal 1: Temp High 2: Fan Error 4: Cover Open 8: Lamp Life 5% or less 16: Lamp Burn-out 32: Lamp Ignition Failure 64: Temp Abnormally High
Lamp	Status		T L P S	- - - - 1	0:Off, 1:On, 2:Retry, 3:Waiting, 4:Lamp Error	0:Off, 4:Lamp Error
	Power Status		T P O W	- - - - 1	1:On, 2:Cooling	0:Standby
	Quantity		T L P N	- - - - 1	1	
	Usage Time (Hour)		T L T T	- - - - 1	0 - 9999 (Integer)	
	Usage Time (Minute)		T L T M	- - - - 1	0, 15, 30, 45	
	Life (Percentage)		T L T L	- - - - 1	0% - 100% (Integer)	
Name	Model Name Check		T N A M	- - - - 1	XGC465XL/XGC435XL	
	Model Name Check		M N R D	- - - - 1	XG-C465X-L/XG-C435X-L	
	Serial No. Check *1		S N R D	- - - - 1	Serial No.	
	Projector Name Setting 1 (First 4 characters) *2		P J N 1	* * * *	OK or ERR	
	Projector Name Setting 2 (Middle 4 characters) *2		P J N 2	* * * *	OK or ERR	
	Projector Name Setting 3 (Last 4 characters) *2		P J N 3	* * * *	OK or ERR	
	Projector Name Check		P J N 0	- - - - 1	Projector Name	
Input Change	Computer1 (RGB1)		I R G B	- - - - 1	OK or ERR	ERR
	Computer2 (RGB2)		I R G B	- - - - 2	OK or ERR	ERR
	DVI (RGB3)		I R G B	- - - - 3	OK or ERR	ERR
		DVI-D-Computer select		I C D S	- - - - 1	OK or ERR
	DVI-D-Video select		I C D S	- - - - 2	OK or ERR	ERR
	S-Video (Video1)		I V E D	- - - - 1	OK or ERR	ERR
	Video (Video2)		I V E D	- - - - 2	OK or ERR	ERR
	Input RGB Check		I R G B	? ? ? ?	1: RGB1 (Computer1), 2: RGB2 (Computer2), 3: RGB3 (DVI), ERR	ERR
	Input Video Check		I V E D	? ? ? ?	1: S-Video, 2: Video, ERR	ERR
	Input Mode Check		I M O D	? ? ? ?	1: RGB, 2: Video	ERR
Input Check		I C H K	? ? ? ?	1: Computer1, 2: Computer2, 3: DVI, 4: S-Video, 5: Video	ERR	
Volume	Volume (0 - 60)		V O L A	- - * *	OK or ERR	ERR
	Volume up/down (-10 - +10)		V O U D	- * * *	OK or ERR	ERR
Keystone	Vertical	-100 - +100	K E Y S	* * * *	OK or ERR	ERR
		-100 - +100	K E Y V	* * * *	OK or ERR	ERR
	Horizontal	-60 - +60	K E Y H	* * * *	OK or ERR	ERR
AV Mute	On		I M B K	- - - - 1	OK or ERR	ERR
	Off		I M B K	- - - - 0	OK or ERR	ERR
Freeze	On		F R E Z	- - - - 1	OK or ERR	ERR
	Off		F R E Z	- - - - 0	OK or ERR	ERR
Eco+Quiet Mode	On		T H M D	- - - - 1	OK or ERR	ERR
	Off		T H M D	- - - - 0	OK or ERR	ERR
Auto Sync	Start		A D J S	- - - - 1	OK or ERR	ERR
Resize	Computer1 (RGB1)	Normal	R A S R	- - - - 1	OK or ERR	ERR
		Stretch	R A S R	- - - - 2	OK or ERR	ERR
		Dot By Dot	R A S R	- - - - 3	OK or ERR	ERR
		Full	R A S R	- - - - 5	OK or ERR	ERR
		Border	R A S R	- - - - 6	OK or ERR	ERR
		Area Zoom	R A S R	- - - - 1	0 OK or ERR	ERR
		V-Stretch	R A S R	- - - - 1	1 OK or ERR	ERR
	Computer2 (RGB2)	Normal	R B S R	- - - - 1	OK or ERR	ERR
		Stretch	R B S R	- - - - 2	OK or ERR	ERR
		Dot By Dot	R B S R	- - - - 3	OK or ERR	ERR
		Full	R B S R	- - - - 5	OK or ERR	ERR
		Border	R B S R	- - - - 6	OK or ERR	ERR
		Area Zoom	R B S R	- - - - 1	0 OK or ERR	ERR
		V-Stretch	R B S R	- - - - 1	1 OK or ERR	ERR

RS-232C Specifications and Commands

CONTROL CONTENTS			COMMAND	PARAMETER	RETURN		
					Power ON	Standby mode (or 40-second startup time)	
Resize	DVI (RGB3)	Normal	R C S R	1	OK or ERR	ERR	
		Stretch	R C S R	2	OK or ERR	ERR	
		Dot By Dot	R C S R	3	OK or ERR	ERR	
		Full	R C S R	5	OK or ERR	ERR	
		Border	R C S R	6	OK or ERR	ERR	
		Area Zoom	R C S R	1 0	OK or ERR	ERR	
	S-Video (Video1)	V-Stretch	R C S R	1 1	OK or ERR	ERR	
		Normal	R A S V	1	OK or ERR	ERR	
		Stretch	R A S V	2	OK or ERR	ERR	
		Border	R A S V	3	OK or ERR	ERR	
		Area Zoom	R A S V	1 0	OK or ERR	ERR	
		V-Stretch	R A S V	1 1	OK or ERR	ERR	
	Video (Video2)	Normal	R B S V	1	OK or ERR	ERR	
		Stretch	R B S V	2	OK or ERR	ERR	
		Border	R B S V	3	OK or ERR	ERR	
		Area Zoom	R B S V	1 0	OK or ERR	ERR	
		V-Stretch	R B S V	1 1	OK or ERR	ERR	
		A L L R E		1	OK or ERR	ERR	
ALL Reset							
Computer1 INPUT	Picture Mode	Standard	R A P S	1 0	OK or ERR	ERR	
		Presentation	R A P S	1 1	OK or ERR	ERR	
		Movie	R A P S	1 2	OK or ERR	ERR	
		Game	R A P S	1 3	OK or ERR	ERR	
		sRGB	R A P S	1 4	OK or ERR	ERR	
	Contrast	-30 ~ +30	R A P I	* * *	OK or ERR	ERR	
	Bright	-30 ~ +30	R A B R	* * *	OK or ERR	ERR	
	Color	-30 ~ +30	R A C O	* * *	OK or ERR	ERR	
	Tint	-30 ~ +30	R A T I	* * *	OK or ERR	ERR	
	Sharp	-30 ~ +30	R A S H	* * *	OK or ERR	ERR	
	Red	-30 ~ +30	R A R D	* * *	OK or ERR	ERR	
	Blue	-30 ~ +30	R A B E	* * *	OK or ERR	ERR	
	CLR Temp	*3	R A C T	* * *	OK or ERR	ERR	
	Progressive	2D Progressive	R A I P		0	OK or ERR	ERR
		3D Progressive	R A I P		1	OK or ERR	ERR
	Film Mode	Auto	R A F M		0	OK or ERR	ERR
		Off	R A F M		1	OK or ERR	ERR
	DNR	Off	R A N R		0	OK or ERR	ERR
		Level 1	R A N R		1	OK or ERR	ERR
		Level 2	R A N R		2	OK or ERR	ERR
		Level 3	R A N R		3	OK or ERR	ERR
	MNR	Off	R A M R		0	OK or ERR	ERR
		Level 1	R A M R		1	OK or ERR	ERR
		Level 2	R A M R		2	OK or ERR	ERR
		Level 3	R A M R		3	OK or ERR	ERR
	Picture Reset		R A R E		1	OK or ERR	ERR
	Signal Type	Auto	I A S I		0	OK or ERR	ERR
		RGB	I A S I		1	OK or ERR	ERR
		Component	I A S I		2	OK or ERR	ERR
	Computer2 INPUT	Picture Mode	Standard	R B P S	1 0	OK or ERR	ERR
			Presentation	R B P S	1 1	OK or ERR	ERR
			Movie	R B P S	1 2	OK or ERR	ERR
			Game	R B P S	1 3	OK or ERR	ERR
			sRGB	R B P S	1 4	OK or ERR	ERR
		Contrast	-30 ~ +30	R B P I	* * *	OK or ERR	ERR
		Bright	-30 ~ +30	R B B R	* * *	OK or ERR	ERR
Color		-30 ~ +30	R B C O	* * *	OK or ERR	ERR	
Tint		-30 ~ +30	R B T I	* * *	OK or ERR	ERR	
Sharp		-30 ~ +30	R B S H	* * *	OK or ERR	ERR	
Red		-30 ~ +30	R B R D	* * *	OK or ERR	ERR	
Blue		-30 ~ +30	R B B E	* * *	OK or ERR	ERR	
CLR Temp		*3	R B C T	* * *	OK or ERR	ERR	
Progressive		2D Progressive	R B I P		0	OK or ERR	ERR
		3D Progressive	R B I P		1	OK or ERR	ERR
Film Mode		Auto	R B F M		0	OK or ERR	ERR
		Off	R B F M		1	OK or ERR	ERR
DNR		Off	R B N R		0	OK or ERR	ERR
		Level 1	R B N R		1	OK or ERR	ERR
		Level 2	R B N R		2	OK or ERR	ERR
		Level 3	R B N R		3	OK or ERR	ERR
MNR		Off	R B M R		0	OK or ERR	ERR
		Level 1	R B M R		1	OK or ERR	ERR
		Level 2	R B M R		2	OK or ERR	ERR
		Level 3	R B M R		3	OK or ERR	ERR
Picture Reset			R B R E		1	OK or ERR	ERR
Signal Type		Auto	I B S I		0	OK or ERR	ERR
		RGB	I B S I		1	OK or ERR	ERR
		Component	I B S I		2	OK or ERR	ERR

RS-232C Specifications and Commands

CONTROL CONTENTS			COMMAND	PARAMETER	RETURN		
					Power ON	Standby mode (or 40-second startup time)	
DVI INPUT	Picture Mode	Standard	R C P S	-- 1 0	OK or ERR	ERR	
		Presentation	R C P S	-- 1 1	OK or ERR	ERR	
		Movie	R C P S	-- 1 2	OK or ERR	ERR	
		Game	R C P S	-- 1 3	OK or ERR	ERR	
		sRGB	R C P S	-- 1 4	OK or ERR	ERR	
	Contrast	-30 -- +30	R C P I	-- * * *	OK or ERR	ERR	
	Bright	-30 -- +30	R C B R	-- * * *	OK or ERR	ERR	
	Color	-30 -- +30	R C C O	-- * * *	OK or ERR	ERR	
	Tint	-30 -- +30	R C T I	-- * * *	OK or ERR	ERR	
	Sharp	-30 -- +30	R C S H	-- * * *	OK or ERR	ERR	
	Red	-30 -- +30	R C R D	-- * * *	OK or ERR	ERR	
	Blue	-30 -- +30	R C B E	-- * * *	OK or ERR	ERR	
	CLR Temp	*3	R C C T	-- * * *	OK or ERR	ERR	
	Progressive	2D Progressive	R C I P	-- -- 0	OK or ERR	ERR	
		3D Progressive	R C I P	-- -- 1	OK or ERR	ERR	
	Film Mode	Auto	R C F M	-- -- 0	OK or ERR	ERR	
		Off	R C F M	-- -- 1	OK or ERR	ERR	
	DNR	Off	R C N R	-- -- 0	OK or ERR	ERR	
		Level 1	R C N R	-- -- 1	OK or ERR	ERR	
		Level 2	R C N R	-- -- 2	OK or ERR	ERR	
		Level 3	R C N R	-- -- 3	OK or ERR	ERR	
	MNR	Off	R C M R	-- -- 0	OK or ERR	ERR	
		Level 1	R C M R	-- -- 1	OK or ERR	ERR	
		Level 2	R C M R	-- -- 2	OK or ERR	ERR	
		Level 3	R C M R	-- -- 3	OK or ERR	ERR	
	Picture Reset		R C R E	-- -- 1	OK or ERR	ERR	
	Signal Type	Auto	I C S I	-- -- 0	OK or ERR	ERR	
		RGB	I C S I	-- -- 1	OK or ERR	ERR	
		Component	I C S I	-- -- 2	OK or ERR	ERR	
	Dynamic Range	Auto	H M C D	-- -- 0	OK or ERR	ERR	
		Standard	H M C D	-- -- 1	OK or ERR	ERR	
		Enhanced	H M C D	-- -- 2	OK or ERR	ERR	
	S-Video INPUT	Picture Mode	Standard	V A P S	-- 1 0	OK or ERR	ERR
Presentation			V A P S	-- 1 1	OK or ERR	ERR	
Movie			V A P S	-- 1 2	OK or ERR	ERR	
Game			V A P S	-- 1 3	OK or ERR	ERR	
sRGB			V A P S	-- 1 4	OK or ERR	ERR	
Contrast		-30 -- +30	V A P I	-- * * *	OK or ERR	ERR	
Bright		-30 -- +30	V A B R	-- * * *	OK or ERR	ERR	
Color		-30 -- +30	V A C O	-- * * *	OK or ERR	ERR	
Tint		-30 -- +30	V A T I	-- * * *	OK or ERR	ERR	
Sharp		-30 -- +30	V A S H	-- * * *	OK or ERR	ERR	
Red		-30 -- +30	V A R D	-- * * *	OK or ERR	ERR	
Blue		-30 -- +30	V A B E	-- * * *	OK or ERR	ERR	
CLR Temp		*3	V A C T	-- * * *	OK or ERR	ERR	
Progressive		2D Progressive	V A I P	-- -- 0	OK or ERR	ERR	
		3D Progressive	V A I P	-- -- 1	OK or ERR	ERR	
Film Mode		Auto	V A F M	-- -- 0	OK or ERR	ERR	
		Off	V A F M	-- -- 1	OK or ERR	ERR	
DNR		Off	V A N R	-- -- 0	OK or ERR	ERR	
		Level 1	V A N R	-- -- 1	OK or ERR	ERR	
		Level 2	V A N R	-- -- 2	OK or ERR	ERR	
		Level 3	V A N R	-- -- 3	OK or ERR	ERR	
MNR		Off	V A M R	-- -- 0	OK or ERR	ERR	
		Level 1	V A M R	-- -- 1	OK or ERR	ERR	
		Level 2	V A M R	-- -- 2	OK or ERR	ERR	
		Level 3	V A M R	-- -- 3	OK or ERR	ERR	
Picture Reset			V A R E	-- -- 1	OK or ERR	ERR	
Video INPUT		Picture Mode	Standard	V B P S	-- 1 0	OK or ERR	ERR
			Presentation	V B P S	-- 1 1	OK or ERR	ERR
			Movie	V B P S	-- 1 2	OK or ERR	ERR
			Game	V B P S	-- 1 3	OK or ERR	ERR
			sRGB	V B P S	-- 1 4	OK or ERR	ERR
		Contrast	-30 -- +30	V B P I	-- * * *	OK or ERR	ERR
		Bright	-30 -- +30	V B B R	-- * * *	OK or ERR	ERR
	Color	-30 -- +30	V B C O	-- * * *	OK or ERR	ERR	
	Tint	-30 -- +30	V B T I	-- * * *	OK or ERR	ERR	
	Sharp	-30 -- +30	V B S H	-- * * *	OK or ERR	ERR	
	Red	-30 -- +30	V B R D	-- * * *	OK or ERR	ERR	
	Blue	-30 -- +30	V B B E	-- * * *	OK or ERR	ERR	
	CLR Temp	*3	V B C T	-- * * *	OK or ERR	ERR	
	Progressive	2D Progressive	V B I P	-- -- 0	OK or ERR	ERR	
		3D Progressive	V B I P	-- -- 1	OK or ERR	ERR	
	Film Mode	Auto	V B F M	-- -- 0	OK or ERR	ERR	
		Off	V B F M	-- -- 1	OK or ERR	ERR	
	DNR	Off	V B N R	-- -- 0	OK or ERR	ERR	
		Level 1	V B N R	-- -- 1	OK or ERR	ERR	
		Level 2	V B N R	-- -- 2	OK or ERR	ERR	
		Level 3	V B N R	-- -- 3	OK or ERR	ERR	
	MNR	Off	V B M R	-- -- 0	OK or ERR	ERR	
		Level 1	V B M R	-- -- 1	OK or ERR	ERR	
		Level 2	V B M R	-- -- 2	OK or ERR	ERR	
		Level 3	V B M R	-- -- 3	OK or ERR	ERR	
	Picture Reset		V B R E	-- -- 1	OK or ERR	ERR	

RS-232C Specifications and Commands

CONTROL CONTENTS		COMMAND	PARAMETER	RETURN	
				Power ON	Standby mode (or 40-second startup time)
Clock	-150 – +150	I N C L	* * * *	OK or ERR	ERR
Phase	-30 – +30	I N P H	- * * *	OK or ERR	ERR
H-position	-150 – +150	I A H P	* * * *	OK or ERR	ERR
V-position	-60 – +60	I A V P	- * * *	OK or ERR	ERR
Fine Sync Adjustment Reset		I A R E	- - - 1	OK or ERR	ERR
AutoSync	On	A A D J	- - - 1	OK or ERR	ERR
	Off	A A D J	- - - 0	OK or ERR	ERR
Video System	AUTO	M E S Y	- - - 1	OK or ERR	ERR
	PAL	M E S Y	- - - 2	OK or ERR	ERR
	SECAM	M E S Y	- - - 3	OK or ERR	ERR
	NTSC4.43	M E S Y	- - - 4	OK or ERR	ERR
	NTSC3.58	M E S Y	- - - 5	OK or ERR	ERR
	PAL-M	M E S Y	- - - 6	OK or ERR	ERR
	PAL-N	M E S Y	- - - 7	OK or ERR	ERR
	PAL-60	M E S Y	- - - 8	OK or ERR	ERR
RGB Frequency Check	Horizontal	T F R Q	- - - 1	kHz(* ** . * or ERR)	ERR
	Vertical	T F R Q	- - - 2	Hz(* ** . * or ERR)	ERR
Image Shift	-96 – +96	L N D S	- * * *	OK or ERR	ERR
Auto V-Keystone	On	A T K S	- - - 1	OK or ERR	ERR
	Off	A T K S	- - - 0	OK or ERR	ERR
OSD Display	On	I M D I	- - - 1	OK or ERR	ERR
	Off	I M D I	- - - 0	OK or ERR	ERR
Background	Logo	I M B G	- - - 1	OK or ERR	ERR
	Blue	I M B G	- - - 3	OK or ERR	ERR
	None	I M B G	- - - 4	OK or ERR	ERR
PRJ Mode	Reverse	I M R E	- - - 1	OK or ERR	ERR
	Off	I M R E	- - - 0	OK or ERR	ERR
	Invert	I M I N	- - - 1	OK or ERR	ERR
	Off	I M I N	- - - 0	OK or ERR	ERR
Language	English	M E L A	- - - 1	OK or ERR	ERR
	Deutsch	M E L A	- - - 2	OK or ERR	ERR
	Español	M E L A	- - - 3	OK or ERR	ERR
	Nederlands	M E L A	- - - 4	OK or ERR	ERR
	Français	M E L A	- - - 5	OK or ERR	ERR
	Italiano	M E L A	- - - 6	OK or ERR	ERR
	Svenska	M E L A	- - - 7	OK or ERR	ERR
	日本語	M E L A	- - - 8	OK or ERR	ERR
	Portugues	M E L A	- - - 9	OK or ERR	ERR
	汉语	M E L A	- - - 10	OK or ERR	ERR
	한국어	M E L A	- - - 11	OK or ERR	ERR
	Русский	M E L A	- - - 12	OK or ERR	ERR
	عربي	M E L A	- - - 13	OK or ERR	ERR
	poliski	M E L A	- - - 14	OK or ERR	ERR
	Türkçe	M E L A	- - - 15	OK or ERR	ERR
	فارسی	M E L A	- - - 16	OK or ERR	ERR
	Magyer	M E L A	- - - 17	OK or ERR	ERR
Auto Power Off	On	A P O W	- - - 1	OK or ERR	ERR
	Off	A P O W	- - - 0	OK or ERR	ERR
Auto Restart	On	A R E S	- - - 1	OK or ERR	ERR
	Off	A R E S	- - - 0	OK or ERR	ERR
System Sound	On	S S N D	- - - 1	OK or ERR	ERR
	Off	S S N D	- - - 0	OK or ERR	ERR
Internal Speaker	On	A S P K	- - - 1	OK or ERR	ERR
	Off	A S P K	- - - 0	OK or ERR	ERR
Audio Out	FAO	A O U T	- - - 1	OK or ERR	ERR
	VAO	A O U T	- - - 2	OK or ERR	ERR
Monitor Out	Enable	M O U T	- - - 1	OK or ERR	ERR
	Disable	M O U T	- - - 0	OK or ERR	ERR
Fan Mode	Normal	H L M D	- - - 0	OK or ERR	ERR
	High	H L M D	- - - 1	OK or ERR	ERR
Lamp Timer Reset *4		L P R E	0 0 0 1	ERR	OK or ERR

*1 Serial No. Check command is used to read out the 12 digits of serial No..

*2 For setting the projector name, send the commands in the order of PJN1, PJN2 and PJN3.

*3 Parameters of CLR Temp settings are as follows.

CLR Temp	Parameter	CLR Temp	Parameter
5500K	_0 5 5	8500K	_0 8 5
6500K	_0 6 5	9300K	_0 9 3
7500K	_0 7 5	10500K	_1 0 5

*4 Lamp Timer Reset command is available only in standby mode.

Setting up the Projector Network Environment

This section describes the basic procedure for using the projector via the network.

If the network is already constructed, the projector's network settings may need to be changed. Please consult your network administrator for assistance with these settings.

You can make network settings both on the projector and on the computer. The following procedure is for making settings on the computer.

Network settings on the computer

1. Connecting the projector to a computer

Connect a LAN cable (Category 5, cross-over type) between the computer and projector.

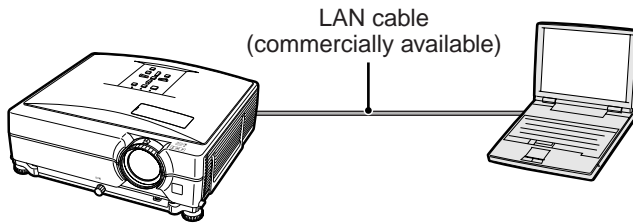

→ Page 19

2. Setting an IP address for the computer

Adjust the IP settings of the computer to enable one-to-one communications with the projector.

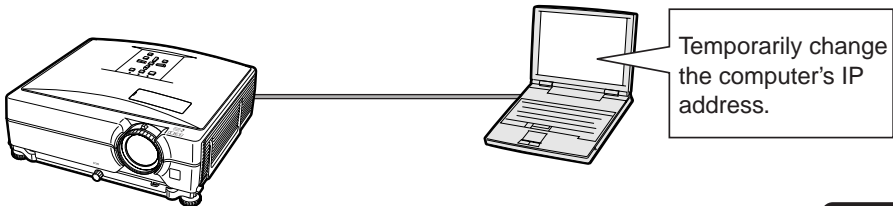

→ Pages 20, 21

3. Setting up a network connection for the projector

Adjust the projector network settings to conform to your network.

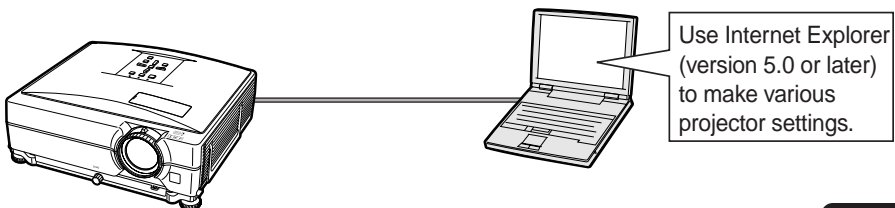

→ Pages 22, 23

- Microsoft®, Windows® and Windows Vista® are registered trademarks of Microsoft Corporation in the United States and/or other countries.
- PJLink is a registered trademark or an application trademark in Japan, the United States and/or other countries/regions.
- All other company or product names are trademarks or registered trademarks of their respective companies.

1. Connecting the Projector to a Computer

Establishing a one-to-one connection from the projector to a computer. Using a commercially available LAN cable (UTP cable, Category 5, cross-over type) you can configure the projector via the computer.

- 1 Disconnect the computer's LAN cable from the existing network.

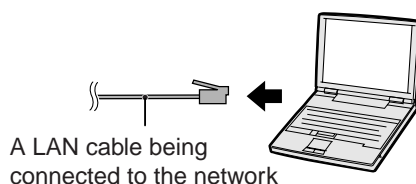

- 2 Connect a commercially available LAN cable (UTP cable, Category 5, cross-over type) to the projector's LAN terminal and connect the other end of the cable to the computer's LAN terminal.

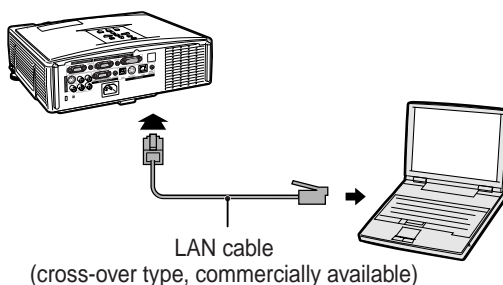

- 3 Plug the power cord into the AC socket of the projector.

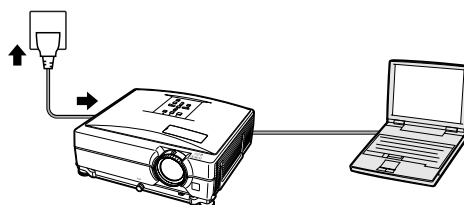

- 4 Turn on the computer.

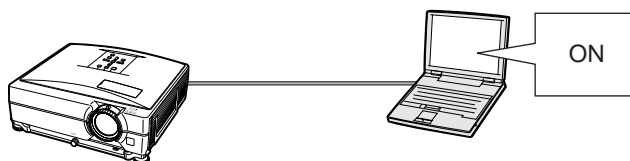

Info

Confirm that the LINK LED on the rear of the projector illuminates. If the LINK LED does not illuminate, check the following :

- The LAN cable is properly connected.
- The power switches of both the projector and the computer are on.

This completes the connection. Now proceed to “2. Setting an IP Address for the Computer”.

Setting up the Projector Network Environment

2. Setting an IP Address for the Computer

The following describes how to make settings in Windows Vista®.

1 Log on the network using the administrator's account for the computer.

2 Click "start", and click "Control Panel".

3 Click "View network status and tasks" of "Network and Internet", and click "View status" in the new window.

- This manual uses examples to explain the operations in Category View. If you are using Classic View, double-click "Network and Sharing Center".

4 Click "Properties".

- When the user account control display is displayed, Click "Continue".

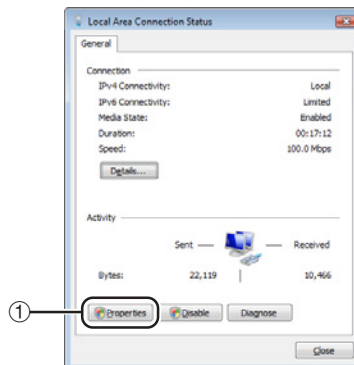
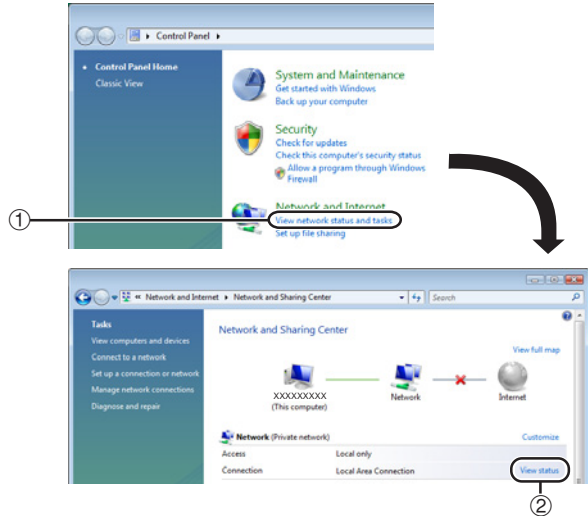
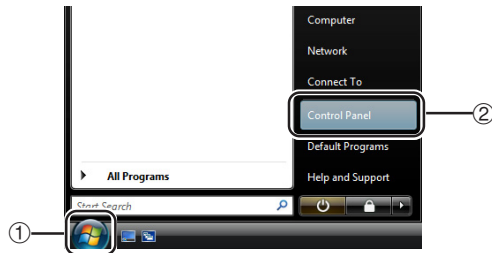

Setting up the Projector Network Environment

- 5** Click “Internet Protocol Version 4 (TCP/IPv4)”, and click the “Properties” button.

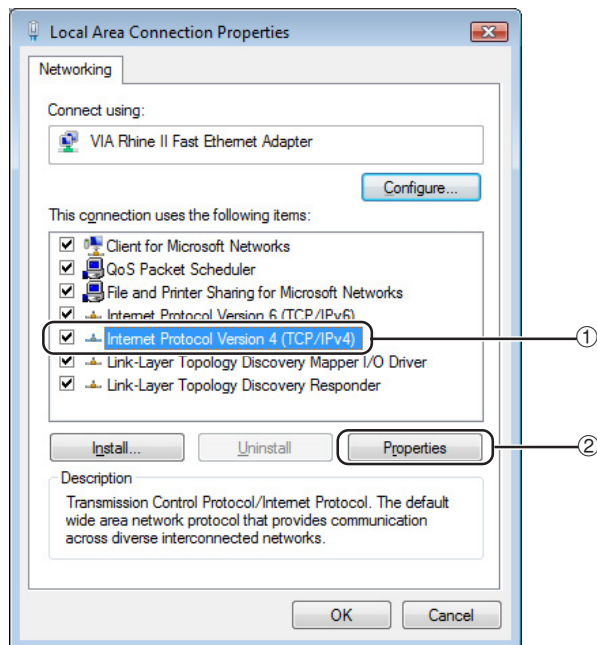

- 6** Confirm or change an IP address for the setup computer.

- ① Confirm and note the current IP address, Subnet mask and Default gateway.

Make sure to note the current IP address, Subnet mask and Default gateway as you will be required to reset them later.

- ② Set temporarily as follows :

IP address : 192.168.150.3

Subnet mask : 255.255.255.0

Default gateway : (Do not input any values.)

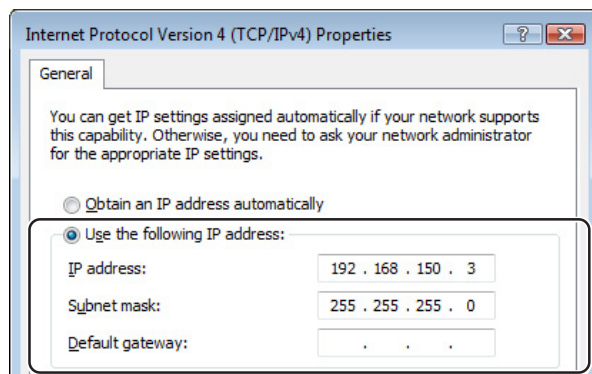

Note

- The factory default settings for the projector are as follows:
DHCP Client : Off
IP address : 192.168.150.2
Subnet mask : 255.255.255.0
Default gateway : 0.0.0.0

- 7** After setting, click the “OK” button, and then restart the computer.

After confirming or setting, proceed to “3. Setting up Network Connection for the Projector”.

Setting up the Projector Network Environment

3. Setting up a Network Connection for the Projector

Settings for such items as the projector's IP address and subnet mask are compatible with the existing network.

Set each item on the projector as follows. (See page 53 of the projector's operation manual for setting.)

DHCP Client : Off

IP Address : 192.168.150.002

Subnet Mask : 255.255.255.000

1 Start Internet Explorer (version 5.0 or later) on the computer, and enter "http://192.168.150.2/" in "Address", and then press the "Enter" key.

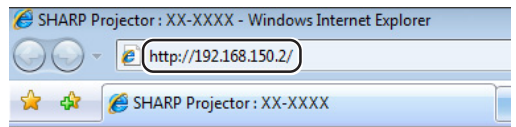

2 If a user name and a password have not yet been set, just click the "OK" button.

- If a user name and a password have been set, input the user name and the password, and click the "OK" button.
- If the user name or password is entered incorrectly three times, an error message will be displayed.
- When you are using Internet Explorer 7, other setup screen may be displayed. In this case, make the proper adjustments for the setup screen.

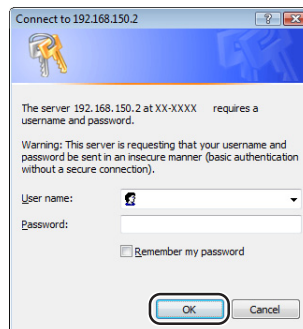

3 When the screen as shown on the right appears, click "TCP/IP".



4 The TCP/IP setting screen appears, ready for network settings for the projector.

Items	Setting example / Remarks
DHCP Client	Select "ON" or "OFF" to determine whether to use DHCP Client.
IP Address	You can set this item when "DHCP Client" is set to "OFF". Factory default setting: 192.168.150.2 Enter an IP address appropriate for the network.
Subnet Mask	You can set this item when "DHCP Client" is set to "OFF". Factory default setting: 255.255.255.0 Set the subnet mask to the same as that of the computer and equipment on the network.
Default Gateway	You can set this item when "DHCP Client" is set to "OFF". Factory default setting: 0.0.0.0 * When not in use, set to "0.0.0.0".
DNS Server	Factory default setting: 0.0.0.0 * When not in use, set to "0.0.0.0".

Note

- Confirm the existing network's segment (IP address group) to avoid setting an IP address that duplicates the IP addresses of other network equipment or computers. If "192.168.150.2" is not used in the network having an IP address of "192.168.150.XXX", you don't have to change the projector IP address.
- For details about each setting, consult your network administrator.

5 Click the "Apply" button.

6 The set values appear. Confirm that the values are set properly, and then click the "Confirm" button.

- Close the browser.
- This completes the network settings.
- After setting items, wait for 10 seconds and then re-access.
- Change the IP address of the setting computer back to its original address, which you have noted down in Step 6-① on page 21, and then connect the computer and the projector to the network.

Network - TCP/IP

DHCP Client	<input checked="" type="radio"/> OFF <input type="radio"/> ON
IP Address	192 168 150 2
Subnet Mask	255 255 255 0
Default Gateway	0 0 0 0 * '0.0.0.0' means 'Using no default gateway.'
Default DNS Server	0 0 0 0 * '0.0.0.0' means 'Using no DNS server.'

Network - TCP/IP

DHCP Client	<input checked="" type="radio"/> OFF <input type="radio"/> ON
IP Address	192 168 150 2
Subnet Mask	255 255 255 0
Default Gateway	0 0 0 0 * '0.0.0.0' means 'Using no default gateway.'
Default DNS Server	0 0 0 0 * '0.0.0.0' means 'Using no DNS server.'



Refresh

Network - TCP/IP

The TCP/IP settings will be changed as below.

DHCP Client : OFF
IP Address : 192.168.150.2
Subnet Mask : 255.255.255.0
Default Gateway : 0.0.0.0
DNS Server : 0.0.0.0

Do you want to change the TCP/IP settings?



After you click "Confirm", if you want to continue to operate this projector via the network, please wait for 10 seconds and then re-access to "192.168.150.2".

Controlling the Projector via LAN

After connecting the projector to your network, enter the projector IP address in “Address” on Internet Explorer (version 5.0 or later) using a computer on the network to start a setup screen that will enable control of the projector via the network.

Controlling the Projector Using Internet Explorer (Version 5.0 or later)

Complete connections to external equipment before starting the operation. (See pages 21-29 of the projector’s operation manual.) Complete the AC cord connection. (See page 30 of the projector’s operation manual.)

Note

- When connecting the projector to the LAN, use a commercially available LAN cable (UTP cable, Category 5, cross-over type). When connecting the projector to a hub, use a straight-through cable.

1 Start Internet Explorer (version 5.0 or later) on the computer.

2 Enter “http://” followed by the projector IP address set by the procedure on page 23 followed by “/” in “Address”, and then press the “Enter” key.

- The factory default setting for the projector : “DHCP Client” is “Off” and IP address is “192.168.150.2”. If you did not change the IP address in “3. Setting up a Network Connection for the Projector” (pages 22-23), enter “http://192.168.150.2”.

3 A screen for controlling the projector appears, ready for performing various status conditions, control, and settings.

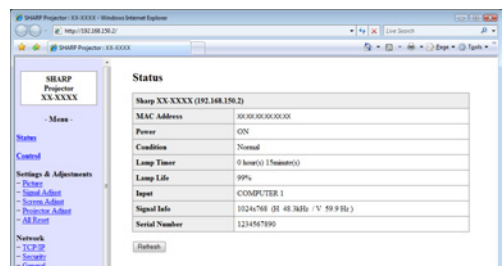
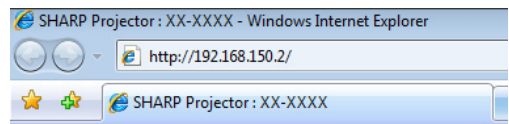

Confirming the Projector Status (Status)

Status

Sharp XX-XXXX (192.168.150.2)	
MAC Address	XXXXXXXXXXXX
Power	ON
Condition	Normal
Lamp Timer	0 hour(s) 15minute(s)
Lamp Life	99%
Input	COMPUTER 1
Signal Info	1024x768 (H 48.3kHz / V 59.9 Hz)
Serial Number	1234567890

Refresh

On this screen, you can confirm the projector status. You can confirm the following items :

- MAC Address
- Power
- Condition
- Lamp Timer
- Lamp Life
- Input
- Signal Info
- Serial Number

Note

- If you click the “Refresh” button before the screen is displayed completely, an error message (“Server Busy Error”) will be displayed. Wait for a moment and then operate again.
- For details about each item, refer to the projector’s operation manual.

Controlling the Projector (Control)

Control

Power	<input type="radio"/> STANDBY <input checked="" type="radio"/> ON
Input Select	COMPUTER1(RGB/Component) ▾
Volume	1 ▾
AV Mute	<input checked="" type="radio"/> OFF <input type="radio"/> ON

Refresh

On this screen, you can perform projector control. You can control the following items :

- Power
- Input Select
- Volume
- AV Mute

Note

- If you click the “Refresh” button before the screen is displayed completely, an error message (“Server Busy Error”) will be displayed. Wait for a moment and then operate again.
- You cannot operate this page while the projector is warming up.
- While the projector is in standby mode, you can only control “Power ON”.
- For details about each item, refer to the projector’s operation manual.

Controlling the Projector via LAN

Setting and Adjusting the Projector (Settings & Adjustments)

Example: "Picture" screen display for COMPUTER1

Settings & Adjustments -Picture COMPUTER

Picture Mode	Presentation
CLR Temp	0
BrilliantColor™	2
Lamp Setting	Bright

Reset

Signal Type	Auto
-------------	------

Refresh

On these screens, you can make projector settings or adjustments. You can set or adjust the following items :

- Picture Mode
- CLR Temp
- Progressive (Video)
- Film Mode
- DNR
- MNR
- Eco+Quiet Mode
- Resolution Setting
- Auto Sync
- Signal Type (Computer, DVI)
- Dynamic Range (DVI)
- Video System (Video)
- Resize
- Auto V-Keystone
- OSD Display
- Background
- Menu Position
- Projection Mode
- Language
- Auto Power Off
- Auto Restart
- System Sound
- Internal Speaker
- Audio Out
- Monitor Out
- RS-232C Speed
- Fan Mode
- All Reset
- Password

Note

- If you click the "Refresh" button before the screen is displayed completely, an error message ("Server Busy Error") will be displayed. Wait for a moment and then operate again.
- You cannot operate this page while the projector is warming up.
- For details about each item, refer to the projector's operation manual.

Setting the Security (Network - Security)

Network - Security

User Name	<input type="text"/>
	(MAX 8 characters)
Password	<input type="password"/>
	(MAX 8 characters)

This user name / password is for accessing via Web browser and Telnet.

*You will need to re-login with the new user name / new password after you change the user name / password.

Accept IP Address	<input checked="" type="radio"/> All IP Addresses <input type="radio"/> From only specific IP addresses
Address 1	<input type="text"/> <input type="text"/> <input type="text"/> <input type="text"/>
Address 2	<input type="text"/> <input type="text"/> <input type="text"/> <input type="text"/>
Address 3	<input type="text"/> <input type="text"/> <input type="text"/> <input type="text"/>

Apply

Refresh

On this screen, you can make settings relating to security.

Items	Description
User Name	Setting of user name for security protection.
Password	Setting of password for security protection.
Accept IP Address	It is possible to set up to three IP addresses allowing connection to the projector.
All IP Addresses	No limits are set to IP addresses connecting to the projector.
From only specific IP addresses	For security improvement, only an IP address set by "Address 1-3" can be connected to the projector.

Note

- User Name and Password can be up to 8 characters.
- You can input the characters below :
a-z, A-Z, 0-9, -, _

Making General Settings for the Network (Network - General)

Network - General

Projector Name	<input type="text" value="XX-XXXX"/> (MAX 12 characters)
Auto Logout Time	<input type="text" value="5"/> minute(s) (0-65535) * If the set value is made 0, the Auto Logout function is disabled.
Data Port	<input type="text" value="10002"/> (1025-65535)
Search Port	<input type="text" value="5006"/> (1025-65535)

On this screen, you can make general settings relating to the network.

Items	Description
Projector Name	Setting the projector name.
Auto Logout Time	Setting the time interval in which the projector will be automatically disconnected from the network in units of a minute (from 1 to 65535 minutes). If the set value is made 0, the Auto Logout function is disabled.
Data Port	Setting the TCP port number used when exchanging data with the projector (from 1025 to 65535).
Search Port	Setting the port number used when searching for the projector (from 1025 to 65535).

After clicking the “Apply” button, the set values appear. Confirm that the values are set properly, and then click the “Confirm” button.

Note

- After setting items, wait for 10 seconds and then re-access.
- Projector Name can be up to 12 characters.
- You can input the characters below :
A-Z, 0-9, -, _ , (,) , space
(When “a-z” are input, they are converted to “A-Z” automatically.)

Setting for Sending E-mail when an Error Occurs (Mail – Originator Settings)

Mail - Originator Settings

SMTP Server	<input type="text"/> (MAX 64 characters)
Originator E-mail Address	<input type="text"/> (MAX 64 characters)
Originator Name	<input type="text"/> (MAX 64 characters)

On this screen, you can make settings for sending e-mail to report when the projector has generated an error.

Items	Setting example / Remarks
SMTP Server	Setting an SMTP server address for e-mail transmission. e.g.1 : 192.168.150.253 e.g.2 : smtp123.sharp.co.jp * When using a domain name, make settings for the DNS server.
Originator E-mail Address	Setting the projector's e-mail address. The e-mail address set here becomes Originator E-mail Address.
Originator Name	Setting the sender's name. The name set here appears in the “Originator Name” column of the body of the message.

Note

- SMTP Server, Originator E-mail Address and Originator Name can be up to 64 characters.
- You can input the characters below:
SMTP Server and Originator E-mail Address :
a-z, A-Z, 0-9, !, #, \$, %, &, *, +, -, /, =, ?, ^, {, |, }, ~, _ , ' , , @ , ` (You can input “@” only one time for “Originator E-mail Address”.)
Originator Name : a-z, A-Z, 0-9, -, _ , (,) , space
- If the settings of “3. Setting up a Network Connection for the Projector” on pages 22 and 23 are incorrectly set, e-mail will not be send.

Setting up the Projector Using RS-232C or Telnet

Connect the projector to a computer using RS-232C or Telnet, and open the SETUP MENU on the computer to carry out various settings for the projector.

When Connecting Using RS-232C

1 Launch general purpose terminal emulator.

2 Input settings for the RS-232C port of the terminal emulator as follows.

Baud Rate : 9600 bps*
Data Length : 8 bit
Parity Bit : None
Stop Bit : 1 bit
Flow Control : None

* This is the factory default setting. If the value of Baud Rate for the projector has been changed, set Baud Rate here according to the changed value on the projector.

3 Input “PJS11234” and press the “Enter” key.

4 “OK” is displayed. Input “PJS25678” and press the “Enter” key within 10 seconds.

5 “User Name:” is displayed. Input the user name and press the “Enter” key.

• If a user name has not yet been set, just press the “Enter” key.

6 “Password:” is displayed. Input the password and press the “Enter” key.

• If a password has not yet been set, just press the “Enter” key.

7 Input “setup” and press the “Enter” key.

• SETUP MENU will be displayed.

▼SETUP MENU

```
-----SETUP MENU-----  
[1]IP Address      [2]Subnet Mask    [3]Default Gateway  
[4]User Name      [5>Password  
[6]RS-232C Baud Rate [7]Projector Name [8]DHCP Client  
[A]Advanced Setup  [D]Disconnect All  
[V]View All Setting [S]Save & Quit    [Q]Quit Unchanged  
  
setup>
```

Note

- User name and password are not set in the factory default settings.
- If the user name or password is entered incorrectly three times, SETUP MENU will be quit.

Setting up the Projector Using RS-232C or Telnet

When Connecting Using Telnet

1 Click “Start” from the Windows® desktop and select “Run”.

2 Enter “telnet 192.168.150.2” in the text box that opens up. (If the IP address of the projector is 192.168.150.2.)

3 Click the “OK” button.

4 “User Name:” is displayed. Input the user name and press the “Enter” key.

- If a user name has not yet been set, just press the “Enter” key.

5 “Password:” is displayed. Input the password and press the “Enter” key.

- If a password has not yet been set, just press the “Enter” key.

6 Input “setup” and press the “Enter” key.

- SETUP MENU will be displayed.

▼SETUP MENU

```
-----SETUP MENU-----
[1]IP Address      [2]Subnet Mask    [3]Default Gateway
[4]User Name      [5]Password
[6]RS-232C Baud Rate [7]Projector Name [8]DHCP Client
[A]Advanced Setup [D]Disconnect All
[V]View All Setting [S]Save & Quit    [Q]Quit Unchanged

setup>
```

Note

- If the IP address has been changed, be sure to enter the new IP address in step 2.
- User name and password are not set in the factory default settings.
- If the user name or password is entered incorrectly three times in steps 4 or 5, SETUP MENU will be quit.

SETUP MENU (Main Menu)

▼ SETUP MENU

-----SETUP MENU-----		
[1]IP Address	[2]Subnet Mask	[3]Default Gateway
[4]User Name	[5]Password	
[6]RS-232C Baud Rate	[7]Projector Name	[8]DHCP Client
[A]Advanced Setup		[D]Disconnect All
[V]View All Setting	[S]Save & Quit	[Q]Quit Unchanged

setup>

[1]IP Address

IP address settings. (Page 34)

[2]Subnet Mask

Subnet mask settings. (Page 34)

[3]Default Gateway

Default gateway settings. (Page 34)

[4]User Name (Factory default setting : Not Required)

Setting of user name for security protection. (Page 34)

[5]Password (Factory default setting : Not Required)

Setting of password for security protection. (Page 35)

[6]RS-232C Baud Rate (Factory default setting : 9600 bps)

Baud rate settings for the RS-232C terminals. (Page 35)

[7]Projector Name

It is possible to assign a projector name. (Page 35)

[8]DHCP Client

DHCP Client settings. (Page 35)

[A]Advanced Setup

Enters ADVANCED SETUP MENU. (Page 36)

[D]Disconnect All

Disconnect all connections. (Page 36)

[V]View All Setting

Displays all setting values. (Page 32)

Can also be used with ADVANCED SETUP MENU.

[S]Save & Quit

Save set values and quit menu. (Page 33)

[Q]Quit Unchanged

Quit menu without saving setting values. (Page 33)



Note

- The factory default settings for the projector are as follows:
 DHCP Client : Off
 IP address : 192.168.150.2
 Subnet mask : 255.255.255.0
 Default gateway : 0.0.0.0

ADVANCED SETUP MENU

▼ ADVANCED SETUP MENU

***** ADVANCED SETUP MENU *****		
[1]Auto Logout Time	[2]Data Port	
[5]Network Ping Test		
[6]Accept IP Addr(1)	[7]Accept IP Addr(2)	[8]Accept IP Addr(3)
[9]Accept All IP Addr	[0]Search Port	

[!]Restore Default Setting
 [Q]Return to Main Menu

advanced>

[1]Auto Logout Time (Factory default setting : 5 minutes)

Setting of time until automatic disconnection of network connection. (Page 36)

[2]Data Port (Factory default setting : 10002)

Setting the TCP port number used when exchanging data. (Page 36)

[5]Network Ping Test

It is possible to confirm that a network connection between the projector and a computer etc. is working normally. (Page 37)

[6]Accept IP Addr(1)

[7]Accept IP Addr(2)

[8]Accept IP Addr(3)

[9]Accept All IP Addr (Factory default setting : Accept All)

For improved security, it is possible to set up to three IP addresses allowing connection to the projector. Set IP addresses can be cancelled using [9] Accept All IP Addr. (Page 37)

[0] Search Port (Factory default setting : 5006)

Setting the port number used when searching for the projector. (Page 38)

[!] Restore Default Setting

Restores all setting values that can be set using the menu to the default state. (Page 38)

[Q]Return to Main Menu

Return to the main SETUP MENU. (Page 38)

Setting up the Projector Using RS-232C or Telnet

Enter number or symbol of item to be selected on the **SETUP MENU**. When setting, input the details to be set. Setting is carried out one item at a time, and saved at the end.

View Setting Detail List ([V]View All Setting)

▼SETUP MENU

```

-----SETUP MENU-----
[1]IP Address      [2]Subnet Mask  [3]Default Gateway
[4]User Name      [5]Password     [6]RS-232C Baud Rate
[7]Projector Name [8]DHCP Client  [A]Advanced Setup
[V]View All Setting [S]Save & Quit  [D]Disconnect All
[Q]Quit Unchanged

setup>v
-----
Model Name       : XX-XXXX
Projector Name   : XX-XXXX
MAC Address      : XX:XX:XX:XX:XX:XX
DHCP Client      : Disabled
IP Address       : 192.168.150.2
Subnet Mask      : 255.255.255.0
Default Gateway  : Not Used
RS-232 Baud Rate : 9600 bps
Password         : Not Required
***** (Advanced Status) *****
Data Port        : 10002
Accept IP Address : Accept All
Auto Logout Time : 5 minutes
Search Port      : 5006
    
```

- ① Enter “v” and press the “Enter” key.
Display all setting values(*).

Set Items

Example: When setting IP Address (change from 192.168.150.2 to 192.168.150.3)

▼SETUP MENU

```

-----SETUP MENU-----
[1]IP Address      [2]Subnet Mask  [3]Default Gateway
[4]User Name      [5]Password     [6]RS-232C Baud Rate
[7]Projector Name [8]DHCP Client  [A]Advanced Setup
[V]View All Setting [S]Save & Quit  [D]Disconnect All
[Q]Quit Unchanged

setup>1
IP Address       : 192.168.150.2 *1
Please Enter     : 192.168.150.3 *2
(change)        -> 192.168.150.3 *2

-----SETUP MENU-----
[1]IP Address      [2]Subnet Mask  [3]Default Gateway
[4]User Name      [5]Password     [6]RS-232C Baud Rate
[7]Projector Name [8]DHCP Client  [A]Advanced Setup
[V]View All Setting [S]Save & Quit  [D]Disconnect All
[Q]Quit Unchanged

setup>v
-----
Model Name       : XX-XXXX
Projector Name   : XX-XXXX
MAC Address      : XX:XX:XX:XX:XX:XX
DHCP Client      : Disabled
IP Address       : 192.168.150.3 *3
Subnet Mask      : 255.255.255.0
Default Gateway  : Not Used
RS-232 Baud Rate : 9600 bps
Password         : Not Required
***** (Advanced Status) *****
Data Port        : 10002
Accept IP Address : Accept All
Auto Logout Time : 5 minutes
Search Port      : 5006
    
```

- ① Enter “1” (number of item to be set), and press the “Enter” key.
Display current IP address (*1).
- ② Enter IP address to be set and press the “Enter” key.
Display IP address after change (*2).
- ③ Enter “v” and press the “Enter” key to verify setting detail list.
IP address is being changed (*3).

Note

- Verification of setting detail list can be omitted.
- Setting details are not effective until they have been saved. (Page 33)
- If an invalid number is entered, an error message (“Parameter Error!”) will be displayed.

Save Settings and Quit ([S]Save & Quit)

Save set values and quit menu.

▼SETUP MENU

```
-----SETUP MENU-----
[1]IP Address      [2]Subnet Mask  [3]Default Gateway
[4]User Name      [5]Password
[6]RS-232C Baud Rate [7]Projector Name [8]DHCP Client
[A]Advanced Setup [D]Disconnect All
[V]View All Setting [S]Save & Quit  [Q]Quit Unchanged

setup>s
All Connection will be disconnect.
Continue(y/n)? y
Apply New setting...Done.
```

- ① Enter “s” and press the “Enter” key.
- ② Enter “y” and press the “Enter” key.

Quit without Saving Settings ([Q]Quit Unchanged)

Quit menu without saving setting values.

▼SETUP MENU

```
-----SETUP MENU-----
[1]IP Address      [2]Subnet Mask  [3]Default Gateway
[4]User Name      [5]Password
[6]RS-232C Baud Rate [7]Projector Name [8]DHCP Client
[A]Advanced Setup [D]Disconnect All
[V]View All Setting [S]Save & Quit  [Q]Quit Unchanged

setup>q
Quit Without Saving(y/n)? y
Setting Unchanged.
```

- ① Enter “q” and press the “Enter” key.
- ② Enter “y” and press the “Enter” key.

Setting up the Projector Using RS-232C or Telnet

The setting procedure for each item will be explained. For the basic procedure, please refer to “Set Items” on page 32.

IP Address Setting ([1]IP Address)

Setting of IP address.

setup>1		①
IP Address	:192.168.150.2	
Please Enter	:192.168.150.3	②
(change)	→ 192.168.150.3	*

- ① Enter “1” and press the “Enter” key.
- ② Enter numerical value to be set and press the “Enter” key.
Display IP address after change (*).

Subnet Mask Setting ([2]Subnet Mask)

Setting subnet mask.

setup>2		①
Subnet Mask	:255.255.255.0	
Please Enter	:255.0.0.0	②
(change)	→ 255.0.0.0	*

- ① Enter “2” and press the “Enter” key.
- ② Enter numerical value to be set and press the “Enter” key.
Display subnet mask after change (*).

Default Gateway Setting ([3]Default Gateway)

Setting default gateway.

setup>3		①
note: “0.0.0.0” means “Using no default gateway.”		
Gateway Address	:0.0.0.0	
Please Enter	:192.168.150.1	②
(change)	→ 192.168.150.1	*

- ① Enter “3” and press the “Enter” key.
- ② Enter numerical value to be set and press the “Enter” key.
Display gateway address after change (*).



Note

- If the values for IP Address, Subnet Mask or Gateway of the projector have been changed via Telnet, the computer cannot be connected to the projector depending on the computer’s network settings.

User Name Setting ([4]User Name)

Carrying out security protection using user name.

setup>4		①
User Name	:	
Please Enter	: XX-XXXX	②
(change)	→ XX-XXXX	*

- ① Enter “4” and press the “Enter” key.
- ② Enter user name and press the “Enter” key.
Display set user name (*).



Note

- User name can be up to 8 characters.
- You can input the characters below :
a-z, A-Z, 0-9, -, _
- In the default state, user name is not set.

Password Setting ([5]Password)

Carrying out security protection using password.

```

setup>5
Password      :
(Please Enter : sharppj)
(change)     -> sharppj
    
```

- ① Enter "5" and press the "Enter" key.
- ② Enter password and press the "Enter" key.
Display set password (*).

Note

- Password can be up to 8 characters.
- You can input the characters below :
a-z, A-Z, 0-9, -, _
- In the default state, the password is not set.

RS-232C Baud Rate Setting ([6]RS-232C Baud Rate)

Setting of baud rate for RS-232C terminals.

```

setup>6
0 ... 9600 bps
1 ... 38400 bps
2 ... 115200 bps
Baud Rate Select[0-2]:2
RS-232C Baud Rate : 115200 bps
    
```

- ① Enter "6" and press the "Enter" key.
- ② Select and enter the number 0, 1 or 2 and press the "Enter" key.
Display set baud rate (*).

Note

- Set the projector's baud rate to the same rate as that used by the computer.

Projector Name Setting ([7]Projector Name)

It is possible to assign a projector name.

```

setup>7
Projector Name : XX-XXXX
(Please Enter  : MY XX-XXXX)
(change)     -> MY XX-XXXX
    
```

- ① Enter "7" and press the "Enter" key.
- ② Enter projector name.
Display set projector name (*).

Note

- Projector name can be up to 12 characters.
- You can input the characters below :
A-Z, 0-9, -, _, (,), space
(When "a-z" are input, they are converted to "A-Z" automatically.)
- It is the same as the name which can be confirmed or set, using RS-232C commands "PJN0", "PJN1", "PJN2" and "PJN3".

DHCP Client Setting ([8]DHCP Client)

Setting DHCP Client to "Enable" or "Disable".

Example: When setting DHCP Client to "Enable"

```

setup>8
note: It sets DHCP Client.
0 ... Disable
1 ... Enable
DHCP Select[0-1]:1
DHCP Client : Enabled

Success get data from DHCP server.
[MAC Address   ]: [XX:XX:XX:XX:XX:XX]
[IP Address    ]: [192.168.150.2]
[Subnet Mask   ]: [255.255.255.0]
[Default Gateway]: [0.0.0.0]
[DHCP IP Address]: [192.168.150.1]
    
```

- ① Enter "8" and press the "Enter" key.
- ② Enter "1" and press the "Enter" key.
Display the obtained values (*).

Setting up the Projector Using RS-232C or Telnet

Disconnecting All Connections ([D]Disconnect All)

It is possible to disconnect all the TCP/IP connections currently recognized by the projector. Even if the COM Redirect port is fixed in the Busy status due to a problem, it is possible to force the Ready status back by carrying out this disconnection.

```
setup>d
Disconnect All Connections(y/n)?y
Now Disconnecting...
```

- 1 Enter “d” and press the “Enter” key.
- 2 Enter “y” and press the “Enter” key.

Note

- If Disconnect All is performed, the connection to the projector via network will be forcibly disconnected.

Entering ADVANCED SETUP MENU

([A]Advanced Setup)

Enters ADVANCED SETUP MENU.

```
setup>a
***** ADVANCED SETUP MENU *****
[1]Auto Logout Time  [2]Data Port
[5]Network Ping Test
[6]Accept IP Addr(1) [7]Accept IP Addr(2) [8]Accept IP Addr(3)
[9]Accept All IP Addr [0]Search Port

[!]Restore Default Setting
[Q]Return to Main Menu

advanced>
```

- 1 Enter “a” and press the “Enter” key.

Setting Auto Logout Time (ADVANCED[1]Auto Logout Time)

If there is no input after a fixed time, the projector automatically disconnects network connection using the Auto Logout function. It is possible to set the time until the projector is automatically disconnected in units of a minute (from 1 to 65535 minutes).

```
advanced>1
Valid range      : 0 to 65535 (minute)
note: if you enter "0", auto logout function will be disable.
Auto Logout Time : 5
Please Enter      :15
(change)         -> 15
```

- 1 Enter “1” and press the “Enter” key.
- 2 Enter numerical value and press the “Enter” key. Display set numerical value (*).

Note

- If the set value is made 0, the Auto Logout function is disabled.
- If an invalid number is entered, an error message (“Parameter Error!”) will be displayed and the screen returns to the ADVANCED SETUP MENU.

Data Port Setting

(ADVANCED[2]Data Port)

Setting of TCP port number. It is possible to set in the range of 1025 to 65535.

```
advanced>2
Valid range      :1025 to 65535
Data Port        :10002
Please Enter      :10005
(change)         -> 10005
```

- 1 Enter “2” and press the “Enter” key.
- 2 Enter numerical value and press the “Enter” key. Display set numerical value (*).

Note

- Set according to need. Normally, use with the factory default setting.

Carrying out Network Ping Test (ADVANCED[5]Network Ping Test)

It is possible to confirm that a network connection between the projector and a computer etc. is working normally.

```

advanced>5
Ping Test IP addr :192.168.150.1
Please Enter :192.168.150.152
(change) --> 192.168.150.152
32 bytes from 192.168.150.152: icmp_seq = 1, time = 0 ms
32 bytes from 192.168.150.152: icmp_seq = 2, time = 0 ms
32 bytes from 192.168.150.152: icmp_seq = 3, time = 0 ms
32 bytes from 192.168.150.152: icmp_seq = 4, time = 0 ms
    
```

- ① Enter “5” and press the “Enter” key.
- ② Enter IP address of device to be tested and press the “Enter” key.
Display entered IP address (*1).
Display test result (*2).

Note

- If the “Enter” key is pressed without entering an IP address, the Ping Test IP address used previously is entered.
- If there is a fault with the connection, “Error: No answer” is displayed after a 5 second retry. In this case, please confirm the settings for the projector and the computer, and contact your network administrator.

Setting of Accept IP Address (ADVANCED[6]Accept IP Addr(1) - [8]Accept IP Addr(3))

It is possible to improve security of the projector by allowing connection from only a prescribed IP address. It is possible to set up to three IP addresses allowing connection to the projector.

```

advanced>6
Accept IP Addr(1) : 0.0.0.0
Please Enter : 192.168.150.152
(change) --> 192.168.150.152
    
```

- ① Enter “6”, “7” or “8” and press the “Enter” key.
- ② Enter numerical value and press the “Enter” key.
Display set numerical value (*).

Note

- To invalidate the Accept IP Address being currently set, enter “0.0.0.0”.
- If there is one or more Accept IP Addr being set, no connections are allowed from IP addresses that are not yet set. They can be cancelled using [9]Accept All IP Addr.

Accepting All IP Addresses (ADVANCED[9]Accept All IP Addr)

Removes IP addresses set with “Accept IP Addr”.

```

advanced>9
Accept All IP Addresses(y/n)? y
    
```

- ① Enter “9” and press the “Enter” key.
- ② Enter “y” and press the “Enter” key.

Note

- At the point in time where “y” was entered, the numerical values for Accept IP Addr(1)-(3) are reset to “0.0.0.0”.
- If “n” is entered, setting is not altered.

Setting up the Projector Using RS-232C or Telnet

Setting of Search Port (ADVANCED[0]Search Port)

Sets the port number used when searching for the projector from the network.

```
advanced>0
Please Enter Port Number for Search from Computer.
Valid range      : 1025 to 65535
Search Port      : 5006
Please Enter      : 5004
(change)         -> 5004 *
```

- ① Enter “0” and press the “Enter” key.
- ② Enter numerical value and press the “Enter” key.
Display set numerical value (*).

Note

- Set according to need. Normally, use with the factory default setting.

Return to Default Settings (ADVANCED[!]Restore Default Setting)

Returns all menu setting values to the default state.

```
advanced>!
Restore All Setting to Default(y/n)? y
— User Setting Initialized —
```

- ① Enter “!” and press the “Enter” key.
- ② Enter “y” and press the “Enter” key.

Note

- If the values for IP Address, Subnet Mask or Gateway of the projector have been returned to the default settings via Telnet, the computer cannot be connected to the projector depending on the computer's network settings.

Return to Main Menu (ADVANCED[Q]Return to Main Menu)

Returns to the main SETUP MENU.

```
advanced>q
-----SETUP MENU-----
[1]IP Address      [2]Subnet Mask    [3]Default Gateway
[4]User Name       [5]Password
[6]RS-232C Baud Rate [7]Projector Name [8]DHCP Client
[A]Advanced Setup  [D]Disconnect All
[V]View All Setting [S]Save & Quit     [Q]Quit Unchanged
setup>
```

- ① Enter “q” and press the “Enter” key.
Returns to the SETUP MENU.

Resetting the Lamp Timer of the Projector via LAN

When the projector is connected to a network, you can use the communications program to send a command to reset the lamp timer. The example below uses Windows® XP as the operating system. When you use Windows Vista®, use other communications program referring to the following steps, because Windows Vista® does not come with HyperTerminal.

1 Click “Start” – “All Programs” – “Accessories” – “Communications” – “HyperTerminal”.

- If you do not have HyperTerminal installed, see the operation manual of your computer.
- Depending on the settings of your computer, you may be required to enter your area code and other details. Enter the information as required.

2 Enter a name in the “Name” field, and click “OK”.



3 If you are required to enter the area code, enter it in the “Area code” field. From the “Connect using” drop-down menu, select “TCP/IP (Winsock)”, and click “OK”.



4 Enter the IP address of the projector in the “Host address” field (see “TCP/IP” on the “Network” menu of the projector), and enter the data port of the projector in the “Port number” field (“10002” is the factory default setting), and click “OK”.



Resetting the Lamp Timer of the Projector via LAN

5 Click “Properties” on the “File” menu.

6 Click the “Settings” tab, and then click “ASCII Setup”.

7 Select the check boxes next to “Send line ends with line feeds”, “Echo typed characters locally”, and “Append line feeds to incoming line ends”, and click “OK”.

- The LAMPRESET Properties window appears, click “OK”.

8 If a user name and/or password is set for the projector, enter the user name and password.

9 Send the lamp reset command “LPRE0001”.

- This command can only be sent when the projector is in standby mode.
- When “OK” is received, this indicates that the lamp was successfully reset.

10 Close HyperTerminal.

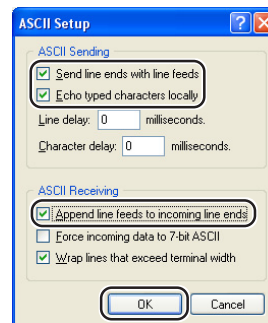
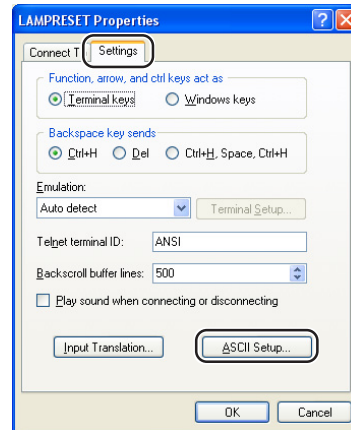
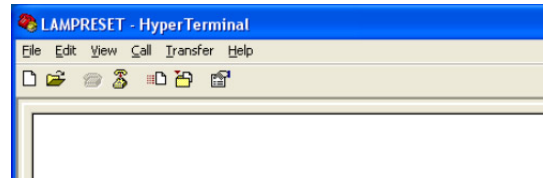

Communication cannot be established with the projector

When connecting the projector using serial-connection

- ◀ Check that the RS-232C terminal of the projector and a computer or the commercially available controller are connected correctly.
- ◀ Check that the RS-232C cable is a cross-over cable.
- ◀ Check that the RS-232C port setting for the projector corresponds to the setting for the computer or the commercially available controller.

When connecting the projector to a computer using network (LAN)-connection

- ◀ Check that the cable's connector is firmly inserted in the LAN terminal of the projector.
- ◀ Check that the cable is firmly inserted into a LAN port for a computer or a network device such as a hub.
- ◀ Check that the LAN cable is a Category 5 cable.
- ◀ Check that the LAN cable is a cross-over cable when connecting the projector to a computer directly.
- ◀ Check that the LAN cable is a straight-through cable when connecting the projector with a network device such as a hub.
- ◀ Check that the power supply is turned on for the network device such as a hub between the projector and a computer.

Check the network settings for the computer and the projector

- ◀ Check the following network settings for the projector.
 - IP Address
Check that the IP address for the projector is not duplicated on the network.
 - Subnet Mask
When the gateway setting for the projector is "0.0.0.0" (Not Used), or the gateway setting for the projector and the default gateway setting for the computer are the same:
 - The subnet masks for the projector and the computer should be the same.
 - The IP address parts shown by the subnet mask for the projector and the computer should be the same.
(Example)
When the IP address is "192.168.150.2" and the subnet mask is "255.255.255.0" for the projector, the IP address for the computer should be "192.168.150.X" (X=3-254) and the subnet mask should be "255.255.255.0".
 - Gateway
When the gateway setting for the projector is "0.0.0.0" (Not Used), or the gateway setting for the projector and the default gateway setting for the computer are the same:
 - The subnets for the projector and the computer should be the same.
 - The IP address parts shown by the subnet mask for the projector and the computer should be the same.
(Example)
When the IP address is "192.168.150.2" and the subnet mask is "255.255.255.0" for the projector, the IP address for the computer should be "192.168.150.X" (X=3-254) and the subnet mask should be "255.255.255.0".

Note

- The factory default settings for the projector are as follows:
DHCP Client : Off
IP address : 192.168.150.2
Subnet mask : 255.255.255.0
Gateway address : 0.0.0.0 (Not Used)
- For network settings for the projector, refer to page [22](#).

Troubleshooting

- ◀ Take the following steps for checking the network settings for the computer.
 1. Open a command prompt.
 - In the case of Windows® 2000: click “START” → “Programs” → “Accessories” → “Command Prompt” in order.
 - In the case of Windows® XP, Windows Vista® : click “START” → “All Programs” → “Accessories” → “Command Prompt” in order.
 2. After launching the command prompt, enter the command “ipconfig”, and press the “Enter” key.

Note

- Communication may not be established even after carrying out the network settings for the computer. In such cases, restart your computer.

C:\>ipconfig

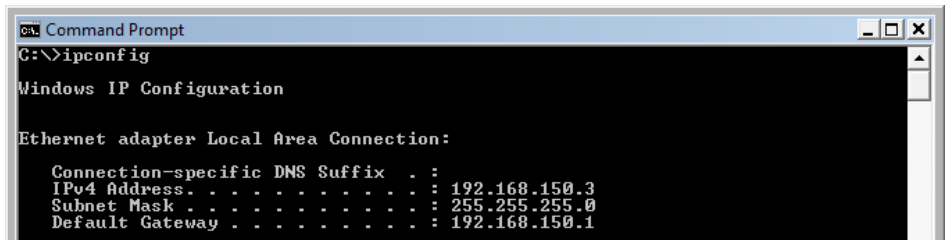

```
Command Prompt
C:\>ipconfig

Windows IP Configuration

Ethernet adapter Local Area Connection:

    Connection-specific DNS Suffix  . : 
    IPv4 Address. . . . . : 192.168.150.3
    Subnet Mask . . . . . : 255.255.255.0
    Default Gateway . . . . . : 192.168.150.1
```

Note

- Usage examples of ipconfig
 - C:\>ipconfig /? displays how to use “ipconfig.exe”.
 - C:\>ipconfig displays the set IP address, subnet mask and default gateway.
 - C:\>ipconfig /all displays all the setting information related to TCP/IP.

3. To return to the Windows® screen, enter “exit” and press the “Enter” key.

- ◀ Check if the “TCP/IP” protocol is operating correctly using the “PING” command. Also, check if an IP address is set.
 1. Open a command prompt.
 - In the case of Windows® 2000: click “START” → “Programs” → “Accessories” → “Command Prompt” in order.
 - In the case of Windows® XP, Windows Vista®: click “START” → “All Programs” → “Accessories” → “Command Prompt” in order.
 2. After launching the command prompt enter a command “PING”.
Entry example C:\>ping XXX.XXX.XXX.XXX
“XXX.XXX.XXX.XXX” should be entered with an IP address to be connected to, such as the projector.
 3. When connecting normally, the display will be as follows.
(The screen may be slightly different depending on the OS type).
<Example> when the IP address connected to is “192.168.150.1”

```

C:\>ping 192.168.150.1

Pinging 192.168.150.1 with 32 bytes of data:

Reply from 192.168.150.1: bytes=32 time<1ms TTL=64
Reply from 192.168.150.1: bytes=32 time<1ms TTL=64
Reply from 192.168.150.1: bytes=32 time<1ms TTL=64
Reply from 192.168.150.1: bytes=32 time<1ms TTL=64

Ping statistics for 192.168.150.1:
    Packets: Sent = 4, Received = 4, Lost = 0 (0% loss),
    Approximate round trip times in milli-seconds:
        Minimum = 0ms, Maximum = 0ms, Average = 0ms
  
```

4. When a command cannot be sent, “Request time out” will be displayed.
Check the network setting again.
If communication can still not be established properly, contact your network administrator.
 5. To return to the Windows® screen, enter “exit” and then press the “Enter” key.
- ◀ When the projector cannot be connected, even though the “PING” command is checked:
 1. When “Accept IP Address” is set on the projector, set the IP address of the PC to be connected.
 2. When a security software is installed on the PC, or when a fire wall has been set up for the network system, connection may not be possible. Consult the system administrator when, for example, you want to change the settings to enable use of the TCP port set as the data port.
 3. When neither of the above two items applies, change the settings for the data port.

A connection cannot be made because you have forgotten your user name or your password.

- ◀ Initialize the settings. (See page 54 of the projector’s operation manual.)
- ◀ After the initialization, carry out setting again.

Wired Remote Control Terminal Specifications

Specifications of wired remote control input

- ø3.5 mm minijack
- External: GND
- Internal: +3.3V

Function and transmission codes

CONTROL ITEM	SYSTEM CODE					DATA CODE								JUDGEMENT CODE	
	C1	C2	C3	C4	C5	C6	C7	C8	C9	C10	C11	C12	C13	C14	C15
STANDBY	1	0	1	1	0	0	1	1	0	1	0	0	1	1	0
ON	1	0	1	1	0	0	1	1	0	1	0	1	0	1	0
KEYSTONE	1	0	1	1	0	1	1	0	1	0	0	0	1	1	0
MENU	1	0	1	1	0	0	0	1	0	0	0	1	1	1	0
▲	1	0	1	1	0	0	0	1	1	1	0	0	1	1	0
◀	1	0	1	1	0	0	0	0	0	1	0	1	0	1	0
▶	1	0	1	1	0	1	1	1	1	0	0	1	0	1	0
▼	1	0	1	1	0	1	0	1	1	1	0	0	1	1	0
ENTER	1	0	1	1	0	1	1	1	0	1	0	1	0	1	0
RETURN	1	0	1	1	0	1	0	0	1	1	0	1	0	1	0
MAGNIFY +	1	0	1	1	0	1	0	1	1	0	1	1	0	1	0
MAGNIFY -	1	0	1	1	0	1	0	1	1	0	1	0	1	1	0
FREEZE	1	0	1	1	0	1	0	1	1	0	0	0	1	1	0

CONTROL ITEM	SYSTEM CODE					DATA CODE								JUDGEMENT CODE	
	C1	C2	C3	C4	C5	C6	C7	C8	C9	C10	C11	C12	C13	C14	C15
VOL +	1	0	1	1	0	0	0	1	0	1	0	0	0	1	0
VOL -	1	0	1	1	0	1	0	1	0	1	0	0	0	1	0
BREAK TIMER	1	0	1	1	0	0	0	1	0	1	0	1	0	1	0
AV MUTE	1	0	1	1	0	1	0	0	1	0	1	1	0	1	0
AUTO SYNC	1	0	1	1	0	0	1	0	1	1	1	1	1	1	0
PICTURE MODE	1	0	1	1	0	1	0	0	1	1	1	0	0	1	0
RESIZE	1	0	1	1	0	0	1	1	1	1	0	1	0	1	0
COMPUTER1	1	0	1	1	0	1	0	1	0	1	1	0	0	1	0
COMPUTER2	1	0	1	1	0	0	1	1	0	1	1	0	0	1	0
DVI-D	1	0	1	1	0	1	0	1	0	1	1	0	1	1	0
S-VIDEO	1	0	1	1	0	0	1	0	0	1	1	0	0	1	0
VIDEO	1	0	1	1	0	1	1	0	0	1	1	0	0	1	0
ECO+QUIET	1	0	1	1	0	1	0	0	1	1	0	0	0	1	0

Wired remote control function code

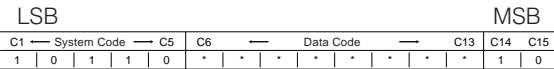

- System codes C1 to C5 are fixed at “10110”.
- Codes C14 and C15 are reverse confirmation bits, with “10” indicating “Front” and “01” indicating “Rear”.

Sharp remote control signal format

Transmission format: 15-bit format

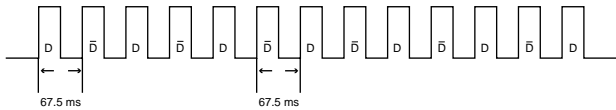

Wave form of output signal: Output using pulse position modulation

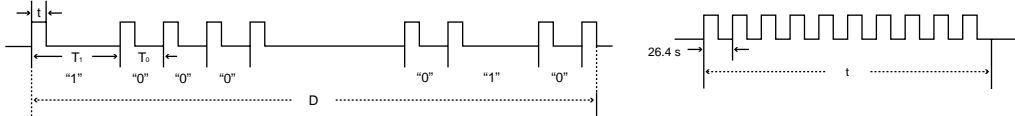

- $t = 264 \mu\text{s}$
- $T_0 = 1.05 \text{ ms}$
- $T_1 = 2.10 \text{ ms}$
- Pulse carrier frequency = 455/12 kHz
- Duty ratio = 1:1

Transmission control code

15 bit

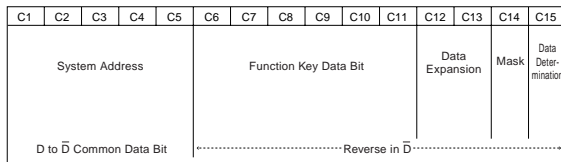

Example of Reverse D to \bar{D}

D	C1	C2	C3	C4	C5	C6	C7	C8	C9	C10	C11	C12	C13	C14	C15
1	0	1	1	0	1	0	0	0	0	0	0	0	0	1	0

\bar{D}	C1	C2	C3	C4	C5	C6	C7	C8	C9	C10	C11	C12	C13	C14	C15
1	0	1	1	0	0	1	1	1	1	1	1	1	1	0	1

Dimensions

Units: inches (mm)

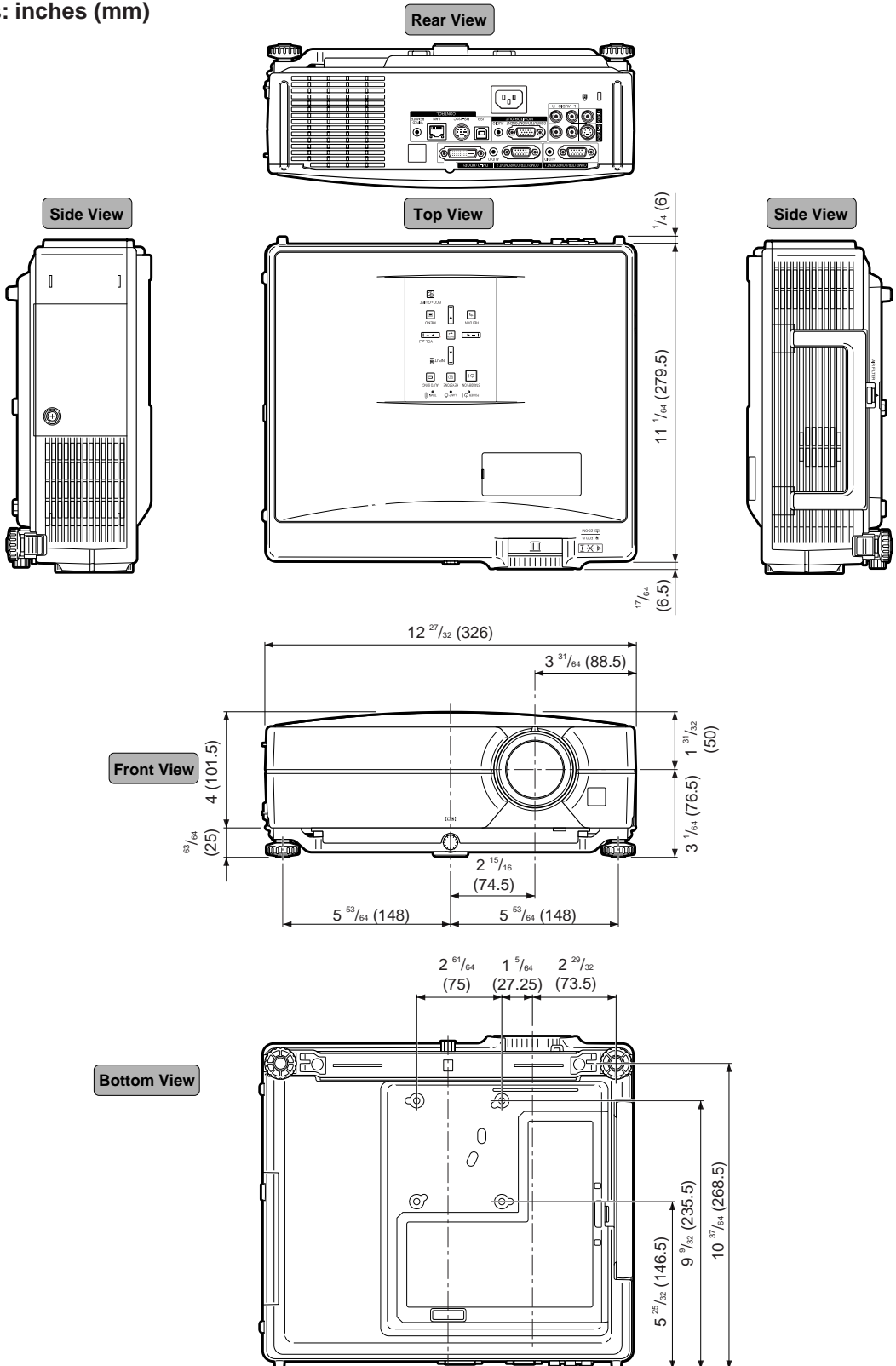

Dimensions

Projector and Lens Dimensions

[When AN-C12MZ is installed]

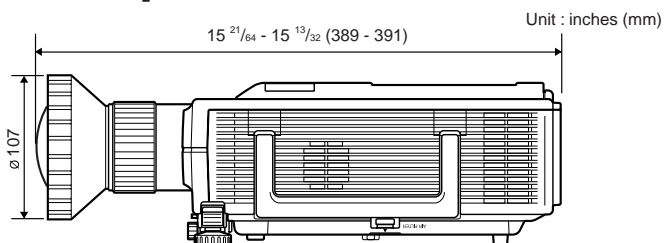

[When AN-C18MZ is installed]

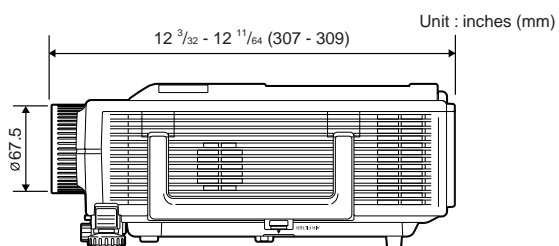

[When AN-C27MZ is installed]

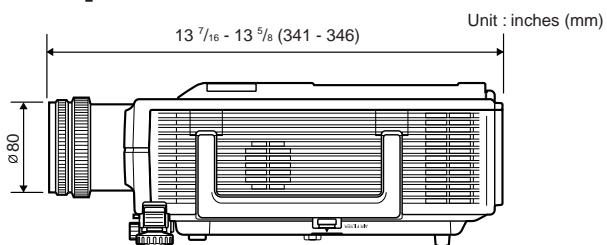

[When AN-C41MZ is installed]

