

# SHARP

## MICRO COMPONENT SYSTEM

MODEL

# XL-35W

OPERATION MANUAL

COMPACT  
**disc**  
DIGITAL AUDIO

**SAVING ENERGY**  
STAND-BY POWER  
CONSUMPTION **0.8w**

Thank you for purchasing this SHARP product.  
To obtain the best performance from this product,  
please read this manual carefully. It will guide you in  
operating your SHARP product.

XL-35W Micro Component System consisting of XL-35W  
(main unit) and CP-XL45H (speaker system).

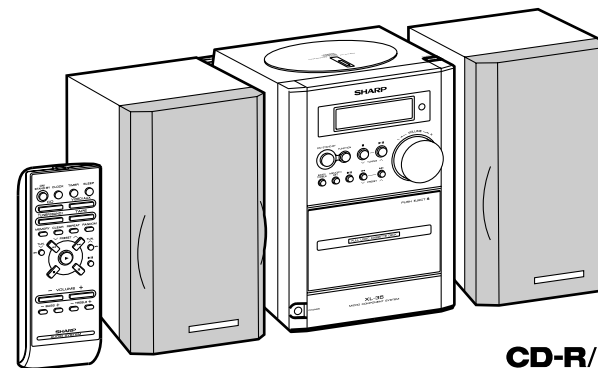

**CD-R/RW**  
Playable

## Special notes

### Warning:

- When the ON/STAND-BY button is set at STAND-BY position, mains voltage is still present inside the unit. When the ON/STAND-BY button is set at STAND-BY position, the unit may be brought into operation by the timer mode or remote control.
- This unit contains no user serviceable parts. Never remove covers unless qualified to do so. This unit contains dangerous voltages, always remove mains plug from the socket before any service operation and when not in use for a long period.
- To prevent fire or shock hazard, do not expose this appliance to dripping or splashing. No objects filled with liquids, such as vases, shall be placed on the apparatus.

### CAUTION

- This product is classified as a CLASS 1 LASER product.
- Use of controls, adjustments or performance of procedures other than those specified herein may result in hazardous radiation exposure.

As the laser beam used in this compact disc player is harmful to the eyes, do not attempt to disassemble the cabinet. Refer servicing to qualified personnel only.

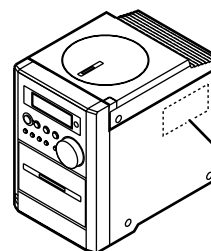

Laser Diode Properties  
 Material: GaAlAs  
 Wavelength: 780 nm  
 Emission Duration: continuous  
 Laser Output: max. 0.6 mW

CAUTION-INVISIBLE LASER RADIATION WHEN OPEN.  
 DO NOT STARE INTO BEAM OR VIEW DIRECTLY WITH  
 OPTICAL INSTRUMENTS.  
 WARNUNG-UNSICHTBARE LASERSTRAHLUNG WENN GERÄT  
 GEÖFFNET. NICHT IN DIE STRAHLUNG SCHAUEN ODER  
 DIREKT MIT OPTISCHEN HILFSMITTELN BETRACHTEN.  
 ATTENTION-RAYON LASER INVISIBLE EN CAS D'OUVERTURE.  
 NE PAS REGARDER LE FAISCEAU DIRECTEMENT OU AVEC DES  
 INSTRUMENTS OPTIQUES.

### Note for users in Australia:

Copyright may exist in material you wish to record. Copying or broadcasting such material without permission of the relevant licensees or owners of the copyright is prohibited by law. SHARP is not in a position to authorise the copying or broadcasting of copyright materials and nothing in this OPERATION MANUAL should be implied as giving that authority.

### For other countries:

Audio-visual material may consist of copyrighted works which must not be recorded without the authority of the owner of the copyright. Please refer to the relevant laws in your country.

## Accessories

Please confirm that the following accessories are included.

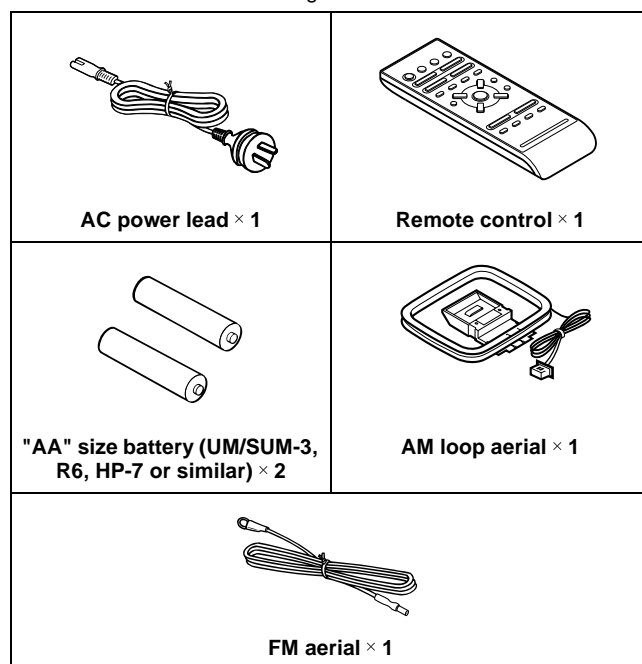

**Note:**  
Only the above accessories are included.

## Contents

XL-35W

	Page
<b>■ General Information</b>	
Precautions .....	3
Controls and indicators .....	4, 5
<b>■ Preparation for Use</b>	
Remote control .....	6
System connections .....	7 - 10
<b>■ Basic Operation</b>	
Sound control .....	11
Setting the clock .....	12
<b>■ CD Playback</b>	
Listening to a CD .....	13 - 15
Programmed play .....	16
<b>■ Radio</b>	
Listening to the radio .....	17
Listening to memorised stations .....	18
<b>■ Tape Playback</b>	
Listening to a cassette tape .....	19, 20
<b>■ Tape Recording</b>	
Recording to a cassette tape .....	21, 22
<b>■ Advanced Features</b>	
Timer and sleep operation .....	23 - 25
Enhancing your system .....	25
<b>■ References</b>	
Troubleshooting chart .....	26, 27
Maintenance .....	27
Specifications .....	28

## Precautions

### ■ General

- Please ensure that the equipment is positioned in a well-ventilated area and that there is at least 10 cm (4") of free space along the sides and back. There must also be a minimum of 20 cm (8") of free space on the top of the unit.

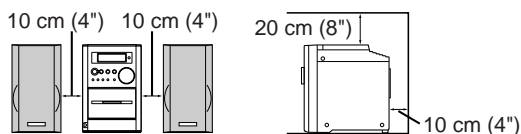

- Use the unit on a firm, level surface free from vibration.
- Keep the unit away from direct sunlight, strong magnetic fields, excessive dust, humidity and electronic/electrical equipment (home computers, facsimiles, etc.) which generate electrical noise.
- Do not place anything on top of the unit.
- Do not expose the unit to moisture, to temperatures higher than 60°C (140°F) or to extremely low temperatures.
- If the system does not work properly, unplug and plug it in again. Then turn on the system.
- In case of an electrical storm, unplug the unit for safety.
- Hold the AC power plug by the head when removing it from the wall socket, as pulling the lead can damage internal wires.
- **Do not remove the outer cover, as this may result in electric shock. Refer internal service to your local SHARP service facility.**

- The ventilation should not be impeded by covering the ventilation openings with items, such as newspapers, tablecloths, curtains, etc.
- No naked flame sources, such as lighted candles, should be placed on the apparatus.
- Attention should be drawn to the environmental aspects of battery disposal.
- This unit should only be used within the range of 5°C - 35°C (41°F - 95°F).

### Warnings:

- The voltage used must be the same as that specified on this unit. Using this product with a higher voltage other than that which is specified is dangerous and may result in a fire or other type of accident causing damage. SHARP will not be held responsible for any damage resulting from use of this unit with a voltage other than that which is specified.
- **CD players use a laser pickup which can damage the eyes if viewed directly. Do not look at the pickup, and do not touch the pickup directly.**

### ■ Volume control

The sound level at a given volume setting depends on speaker efficiency, location, and various other factors. It is advisable to avoid exposure to high volume levels, to avoid this do not turn the volume on to full at switch on and listen to music at moderate levels.

## Controls and indicators

XL-35W

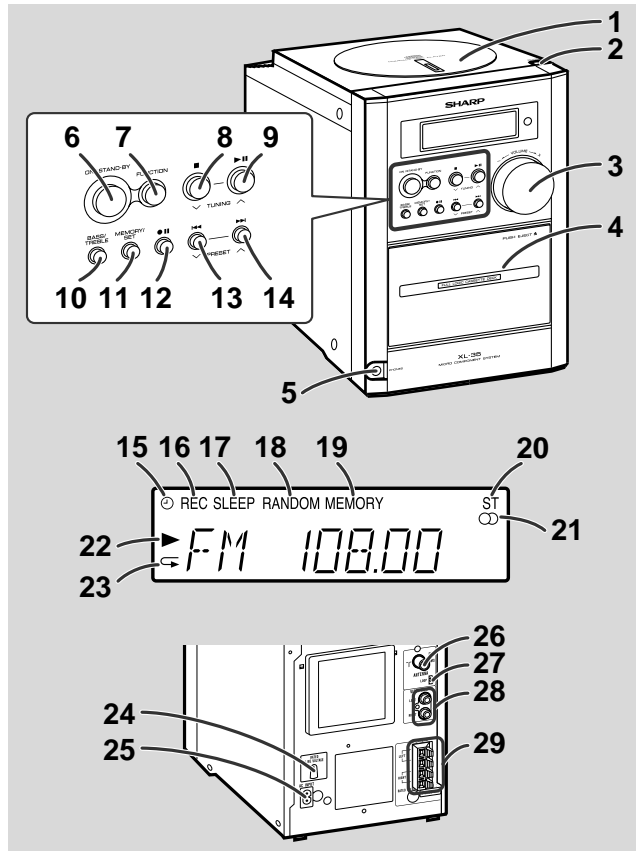

	Reference page
1. CD Compartment .....	13
2. CD Eject Button .....	13
3. Volume Control .....	11
4. Cassette Compartment .....	19
5. Headphone Socket .....	14
6. On/Stand-by Button .....	9
7. Function Selector Button .....	10, 13, 17, 19
8. CD or Tape Stop, Tuning Down Button .....	14, 17, 20
9. CD Play or Pause, Tape Play, Tuning Up Button .....	13, 14, 17, 19, 21
10. Bass/Treble Selector Button .....	11
11. Memory/Set Button .....	16, 18
12. Tape Record Pause Button .....	21, 22
13. CD Track Down or Fast Reverse, Tape Rewind, Tuner Preset Down Button .....	14, 15, 18, 20
14. CD Track Up or Fast Forward, Tape Fast Forward, Tuner Preset Up Button .....	14, 15, 18, 20
15. Timer Play Indicator	
16. Tape Record Indicator	
17. Sleep Indicator	
18. CD Random Play Indicator	
19. Memory Indicator	
20. FM Stereo Mode Indicator	
21. FM Stereo Receiving Indicator	
22. CD Play Indicator	
23. CD Repeat Play Indicator	
24. AC Voltage Selector .....	9
25. AC Power Input Socket .....	9
26. FM 75 Ohms Aerial Socket .....	7, 8
27. AM Loop Aerial Socket .....	7, 8
28. Video/Auxiliary (Audio Signal) Input Sockets .....	25
29. Speaker Terminals .....	7, 8

General Information

## Controls and indicators (continued)

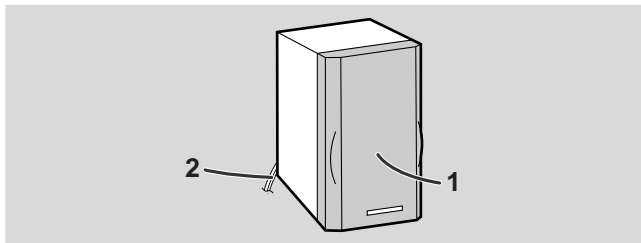

- 1. Full-Range Speaker
- 2. Speaker Wire

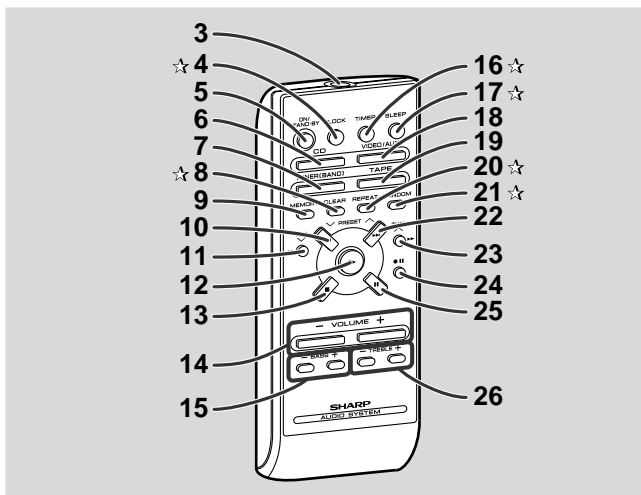

Buttons with "☆" mark in the illustration or highlighted in bold on the right can be operated on the remote control only.

	Reference page
3. Remote Control Transmitter	6
☆ 4. <b>Clock Button</b>	<b>12</b>
5. On/Stand-by Button	6
6. CD Button	13
7. Tuner and Band Selector Button	17
☆ 8. <b>Clear Button</b>	<b>16, 18</b>
9. Memory Button	16, 18
10. CD Track Down, Tuner Preset Down Button	12, 14, 15, 18
11. CD Fast Reverse, Tuning Down, Tape Rewind Button	15, 17, 20
12. CD or Tape Play Button	13, 19
13. CD or Tape Stop Button	14, 20
14. Volume Up and Down Buttons	11, 23
15. Bass Up and Down Buttons	11
16. <b>Timer Button</b>	<b>23</b>
17. <b>Sleep Button</b>	<b>24</b>
18. Video/Auxiliary Button	25
19. Tape Button	19
20. <b>Repeat Button</b>	<b>15</b>
21. <b>Random Button</b>	<b>15</b>
22. CD Track Up, Tuner Preset Up Button	12, 14, 15, 18
23. CD Fast Forward, Tuning Up, Tape Fast Forward Button	15, 17, 20
24. Tape Record Pause Button	21, 22
25. CD Pause Button	14
26. Treble Up and Down Buttons	11

## Remote control

XL-35W

### ■ Battery installation

- 1 **Remove the battery cover.**
- 2 **Insert the supplied batteries according to the direction indicated in the battery compartment.**  
When inserting or removing the batteries, push them towards the ⊖ battery terminals.
- 3 **Replace the cover.**

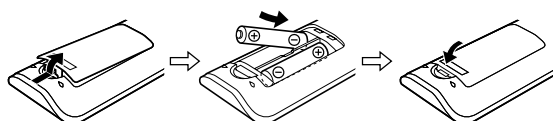

### Precautions for battery use:

- Replace all old batteries with new ones at the same time.
- Do not mix old and new batteries.
- Remove the batteries if the unit is not to be used for long periods of time. This will prevent potential damage due to battery leakage.

### Caution:

- Do not use rechargeable batteries (nickel-cadmium battery, etc.).
- Installing the batteries incorrectly may cause the unit to malfunction.

### Notes concerning use:

- Replace the batteries if the operating distance is reduced or if the operation becomes erratic. Purchase 2 "AA" size batteries (UM/SUM-3, R6, HP-7 or similar).
- Periodically clean the transmitter on the remote control and the sensor on the unit with a soft cloth.
- Exposing the sensor on the unit to strong light may interfere with operation. Change the lighting or the direction of the unit.
- Keep the remote control away from moisture, heat, shock, and vibrations.

### ■ Test of the remote control

Check the remote control after checking all connections have been made correctly. (See pages 7 - 9.)

Face the remote control directly to the remote sensor on the unit.

**The remote control can be used within the range shown below:**  
Press the ON/STAND-BY button. Does the power turn on? Now, you can enjoy the music.

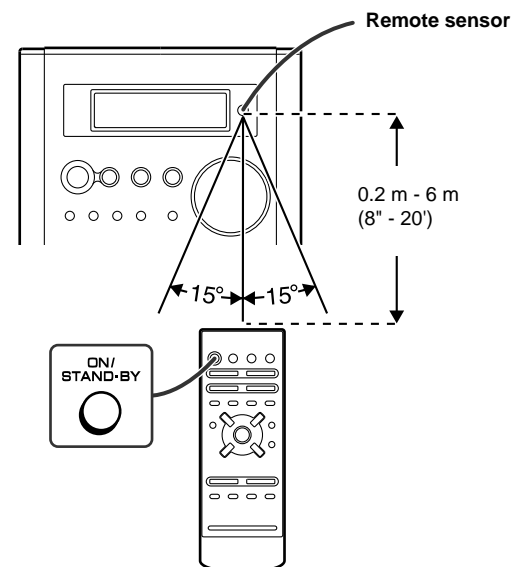

Preparation for Use

# System connections

Preparation for Use

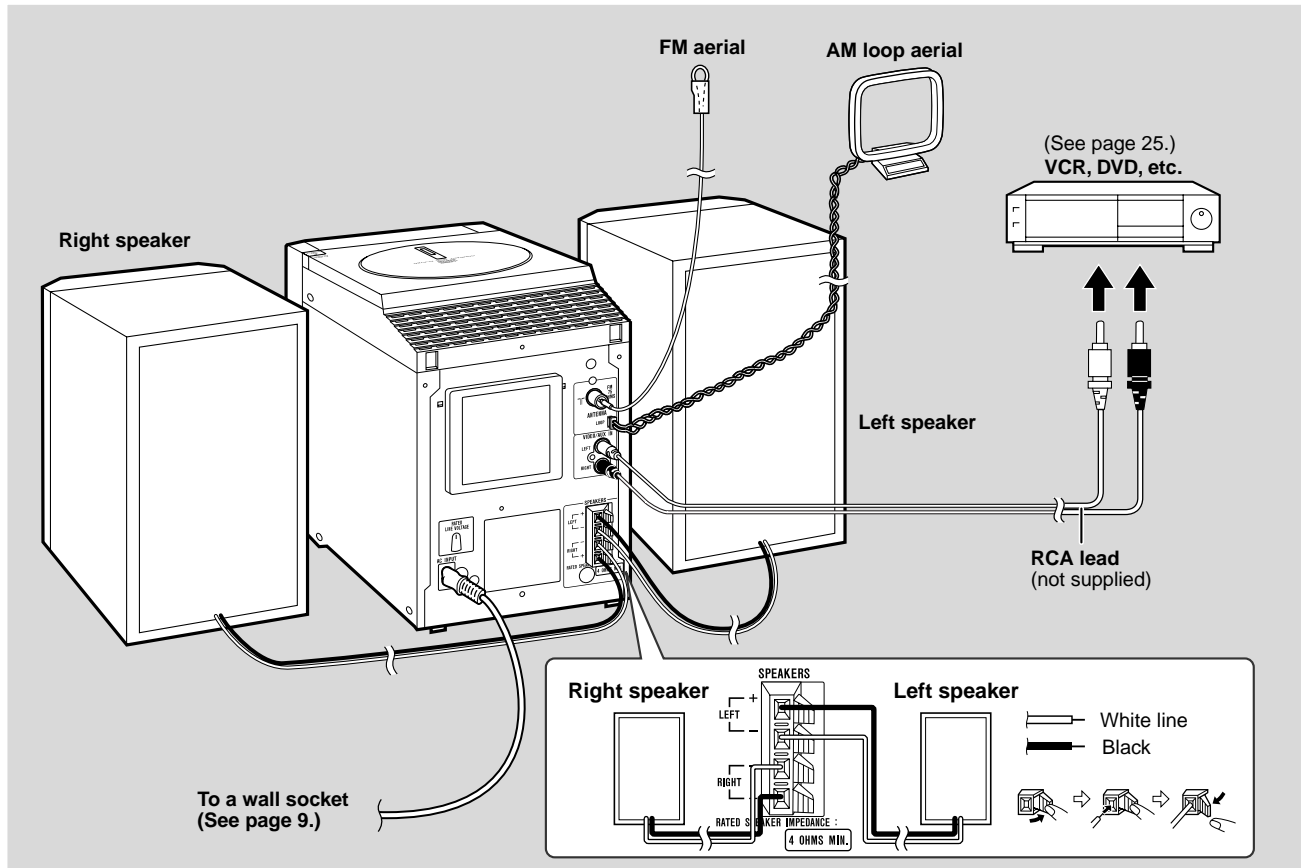

■ **Aerial connection**

**Supplied FM aerial:**

Connect the FM aerial wire to the FM 75 OHMS socket and position the FM aerial wire in the direction where the strongest signal can be received.

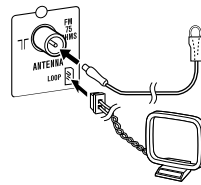

**Supplied AM loop aerial:**

Connect the AM loop aerial to the LOOP socket. Position the AM loop aerial for optimum reception. Place the AM loop aerial on a shelf, etc., or attach it to a stand or a wall with screws (not supplied).

**Note:**

Placing the aerial on the unit or near the AC power lead may cause noise pickup. Place the aerial away from the unit for better reception.

**Installing the AM loop aerial:**

< Assembling >

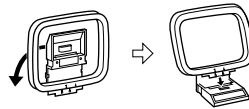

< Attaching to the wall >

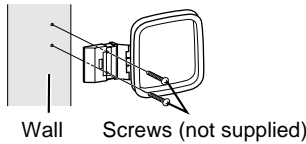

**External FM aerial:**

Use an external FM aerial if you require better reception. Consult your dealer.

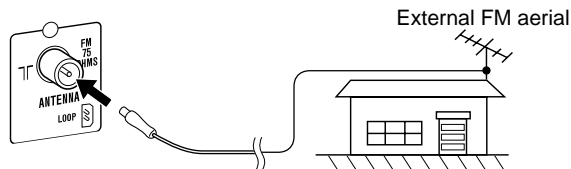

■ **Speaker connection**

Connect the wire with the white line to the minus (-) terminal and the black wire to the plus (+) terminal.

**Caution:**

- Use speakers with an impedance of 4 ohms or more, as lower impedance speakers can damage the unit.
- Do not mistake the right and the left channels. The right speaker is the one on the right side when you face the unit.
- **Do not let the bare speaker wires touch each other.**

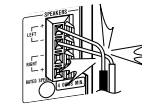

**Incorrect**

**Placing the speaker system:**

There is no physical distinction between the right and the left speakers.

**Note:**

The speaker grilles are not removable.

Preparation for Use

## System connections (continued)

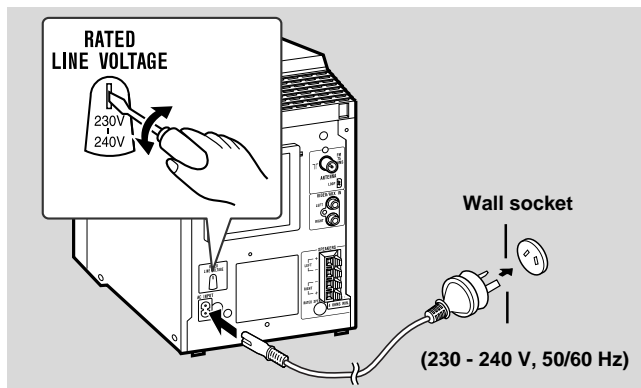

### ■ Setting the AC voltage selector

Check the setting of the AC voltage selector located on the rear panel before plugging the unit into a wall socket. If necessary, adjust the selector to correspond to the AC power voltage used in your area.

Turn the selector with a screwdriver until the appropriate voltage number appears in the window (110 V, 127 V, 220 V or 230 V - 240 V AC).

### ■ Connecting the AC power lead

After checking all the connections have been made correctly, connect the AC power lead to the AC power input socket, then into the wall socket.

#### Notes:

- Unplug the AC power lead from the wall socket if the unit will not be in use for a prolonged period of time.
- **Never use a power lead other than the one supplied. Use of a power lead other than the one supplied may cause an electric shock or fire.**

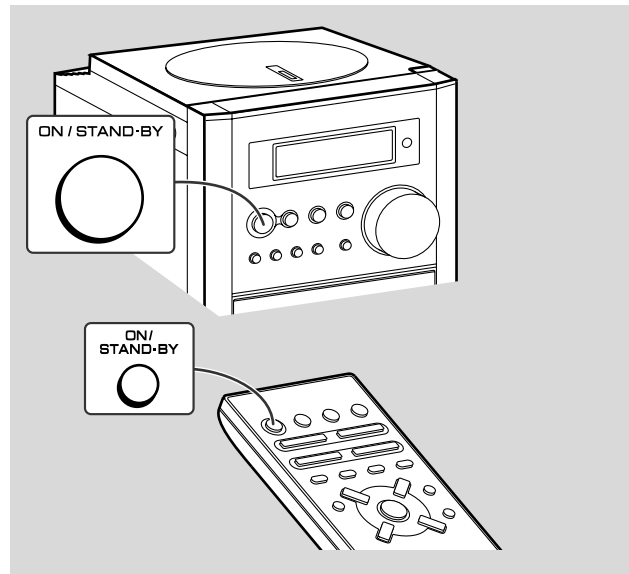

### ■ To turn the power on

Press the ON/STAND-BY button to turn the power on.

#### To set the unit to the stand-by mode:

Press the ON/STAND-BY button again.

### ■ Setting the AM/FM interval

The International Telecommunication Union (ITU) has established that member countries should maintain either a 10 kHz or 9 kHz interval between broadcasting frequencies of AM stations and 100 kHz or 50 kHz for FM stations. The illustration shows the 50/9 kHz zones (regions 1 and 3), and the 100/10 kHz zone (region 2).

This product is not equipped with a span selector. However, it will be adjusted to a 9 kHz AM (50 kHz FM) interval when shipped from the factory.

Before using the unit, be sure to set it to the AM/FM tuning interval (span) used in your area.

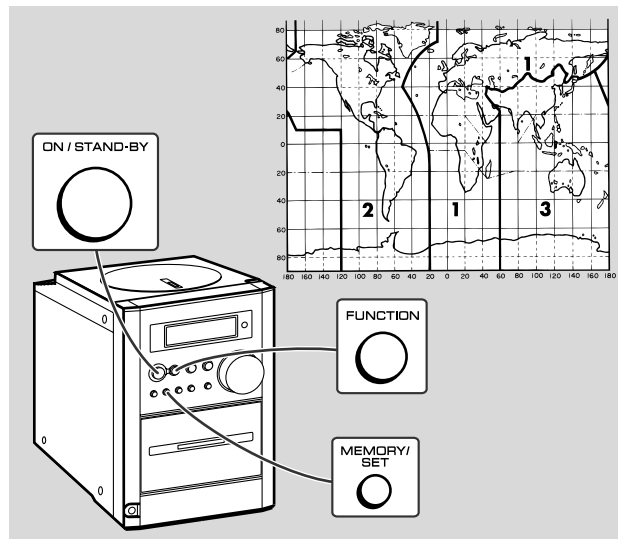

#### To check the tuning span currently selected:

- 1 Press the ON/STAND-BY button to turn the power on.
- 2 Press the FUNCTION button until "AM" appears on the display.
  - If "AM 531 kHz" is displayed, it means that AM stations have been adjusted for a 9 kHz span and FM stations for 50 kHz span. If "AM 530 kHz" is displayed, AM stations have been adjusted for a 10 kHz span and FM stations for 100 kHz span.

#### To change from a 9 kHz AM (50 kHz FM) interval to a 10 kHz AM (100 kHz FM) interval:

- 1 Press the ON/STAND-BY button to enter the stand-by mode.
- 2 Hold down the MEMORY/SET button and the FUNCTION button for at least 4 seconds. Release the buttons when "AM SP 10 kHz" and "FM SP 100 kHz" are displayed alternately.
  - The clock display will reappear.

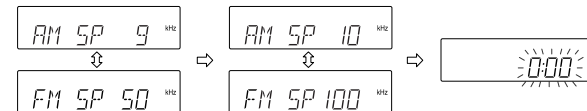

#### To return to a 9 kHz AM (50 kHz FM) interval:

- 1 Press the ON/STAND-BY button to enter the stand-by mode.
- 2 Hold down the MEMORY/SET button and the FUNCTION button for at least 4 seconds. Release the buttons when "AM SP 9 kHz" and "FM SP 50 kHz" are displayed alternately.
  - The clock display will reappear.

#### Caution:

- When the unit is left for a few hours after the span has been switched and the AC power lead disconnected, the AM span will be automatically returned to 9 kHz (FM span to 50 kHz). If this happens, set the span again.
- When the span is switched, all the memorised stations will be cancelled.

## Sound control

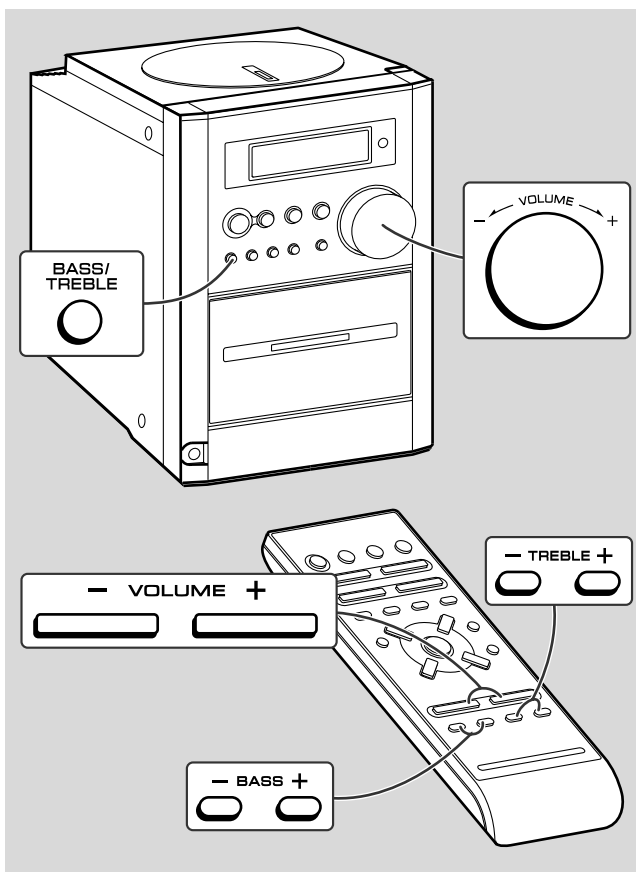

### ■ Adjusting the volume

#### Main unit operation:

When the VOLUME control is turned clockwise, the volume will increase. When it is turned anti-clockwise, the volume will decrease.

#### Remote control operation:

Press the VOLUME + button to increase the volume and the VOLUME - button to decrease the volume.

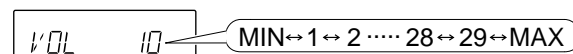

### ■ Adjusting the bass

#### Main unit operation:

- 1 Press the BASS/TREBLE button to select "BASS".
- 2 Within 5 seconds, turn the VOLUME control to adjust the bass.

#### Remote control operation:

Press the BASS (- or +) button to adjust the bass.

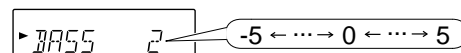

### ■ Adjusting the treble

#### Main unit operation:

- 1 Press the BASS/TREBLE button to select "TRE".
- 2 Within 5 seconds, turn the VOLUME control to adjust the treble.

#### Remote control operation:

Press the TREBLE (- or +) button to adjust the treble.

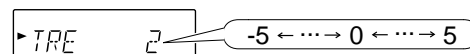

## Setting the clock

XL-35W

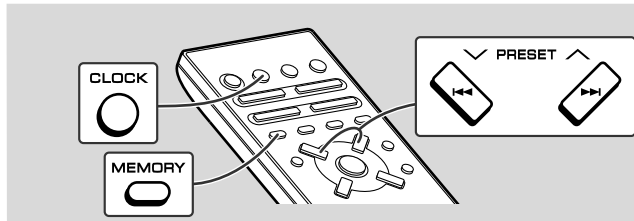

This may be operated only with the remote control.  
In this example, the clock is set for the 24-hour (0:00) display.

- 1 Press the CLOCK button and within 3 seconds, press the MEMORY button.**



- 2 Within 1 minute, press the PRESET (∨ or ∧) button to select 24-hour or 12-hour display and then press the MEMORY button.**



"0:00" → The 24-hour display will appear.  
(0:00 - 23:59)

"AM 12:00" → The 12-hour display will appear.  
(AM 12:00 - PM 11:59)

Note that this can only be set when the unit is first installed or it has been reset. (Refer to "Clearing all the memory (reset)" on page 27.)

- 3 Within 1 minute, press the PRESET (∨ or ∧) button to adjust the hour and then press the MEMORY button.**

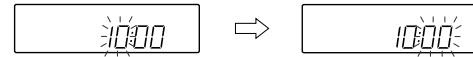

When the 12-hour display is selected, "AM" will change automatically to "PM".

- 4 Within 1 minute, press the PRESET (∨ or ∧) button to adjust the minutes and then press the MEMORY button.**

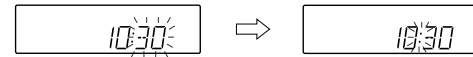

The clock starts from "0" second. (Seconds are not displayed.)

**To confirm the time display when the power is on:**

Press the CLOCK button.

The time display will appear for about 5 seconds.

**Note:**

The "0:00" or time will flash when the AC power supply is restored after a power failure or unplugging the unit. Readjust the clock as follows.

**To readjust the clock:**

Perform "Setting the clock" from the beginning. If the time is flashing, step 2 (for selecting the 24-hour or 12-hour display) will be skipped.

**To change the 24-hour or 12-hour display:**

- 1 Clear all the programmed contents. [Refer to "Clearing all the memory (reset)" on page 27 for details.]
- 2 Perform "Setting the clock" from the beginning.

## Listening to a CD

This system can play audio CD-R and CD-RW discs just like CD discs, but cannot perform recording. Playback of audio CD-R or CD-RW may not be performed depending on the disc state or the device you used for recording.

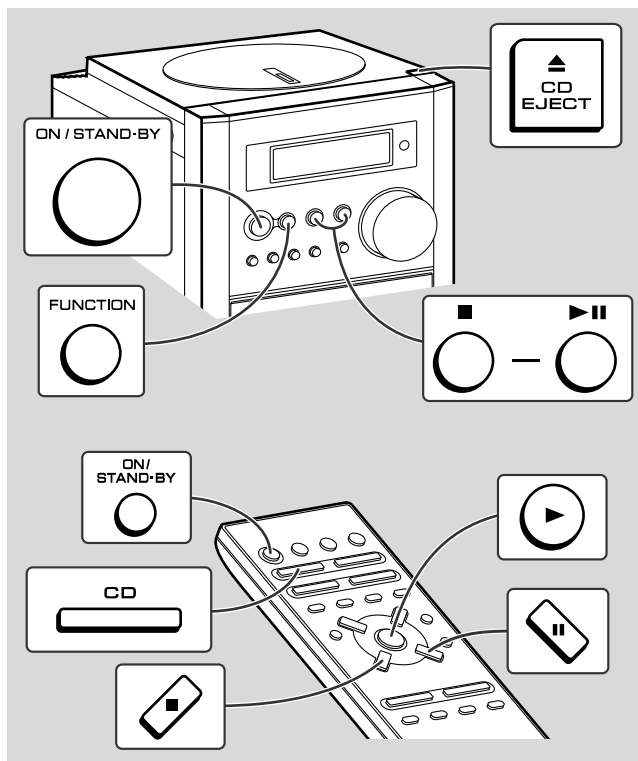

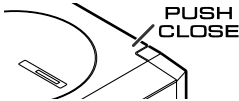
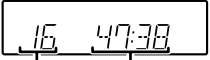
- 1 Press the ON/STAND-BY button to turn the power on.**
- 2 Press the FUNCTION button until "CD STOP" appears on the display.**  
When operating with the remote control, press the CD button.
- 3 Press the ▲ CD EJECT button to open the CD compartment.**
- 4 Place a CD on the spindle, label side up.**

- 5 Close the CD compartment by firmly pushing the corner marked "PUSH CLOSE".**



Total number of tracks      Total playing time
- 6 Press the ►II (►) button to start playback from track 1.**  
When the last track on the disc has finished playing, the CD player will automatically stop.

**To interrupt playback:****Main unit operation:**

Press the ►|| button.

To resume playback from the same point, press the ►|| button again.

**Remote control operation:**

Press the || button.

To resume playback from the same point, press the ► button.

**To stop playback:**

Press the ■ button.

**To remove the CD:**

Whilst in the stop mode, press the ▲ CD EJECT button.

**After use:**

Press the ON/STAND-BY button to enter the power stand-by mode.

**Caution:**

- If a disc is damaged, dirty, or loaded upside down, "NO DISC" or "READ ERR" will appear on the display.
- Keep foreign objects out of the CD compartment.
- Subjecting the unit to shock or vibration may cause mistracking.
- When the unit is not being used, be sure to close the CD compartment. If it is left open, the lens may be covered with dust and the unit may not operate properly.
- If TV or radio interference occurs during CD operation, move the unit away from the TV or radio.

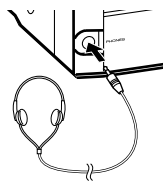
**■ Headphones**

- Before plugging in or unplugging the headphones, reduce the volume.
- Be sure your headphones have a 3.5 mm (1/8") diameter plug and are between 16 ohms and 50 ohms impedance. The recommended impedance is 32 ohms.
- Plugging in the headphones disconnects the speakers automatically. Adjust the volume using the VOLUME control.

**■ Care of compact discs**

Compact discs are fairly resistant to damage, however mistracking can occur due to an accumulation of dirt on the disc surface. Follow the guidelines below for maximum enjoyment from your CD collection and player.

- Do not write on either side of the disc, particularly the non-label side from which signals are read. Do not mark this surface.
- Keep your discs away from direct sunlight, heat, and excessive moisture.
- Always hold the CDs by the edges. Fingerprints, dirt, or water on the CDs can cause noise or mistracking. If a CD is dirty or does not play properly, clean it with a soft, dry cloth, wiping straight out from the centre, along the radius.

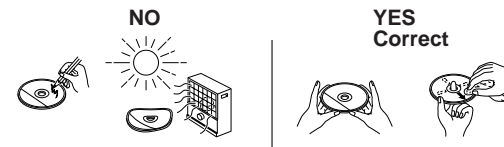
**■ To locate the beginning of a track****To move to the beginning of the next track:**

Press the ►► button for less than 0.5 seconds during playback.



- You can skip to any track by pressing the ►► button repeatedly until the desired track number appears.

**To restart the track being played:**

Press the ◀◀ button for less than 0.5 seconds during playback.



- You can skip to any track by pressing the ◀◀ button repeatedly until the desired track number appears.

## Listening to a CD (continued)

### ■ To locate the desired portion

#### For audible fast forward:

Press and hold down the ►► button on the main unit or the ►► button on the remote control during playback.

#### For audible fast reverse:

Press and hold down the ◀◀ button on the main unit or the ◀◀ button on the remote control during playback.

#### Notes:

- Normal playback will resume when the ◀◀ (◀◀) or ►► (►►) button is released.
- When the end of the last track is reached during fast forward, "END" will appear on the display and CD operation will be paused. When the beginning of the first track is reached during fast reverse, playback will start when you release the ◀◀ button.

### ■ Random play

The tracks can be played in random order automatically.

Press the RANDOM button to begin random play.

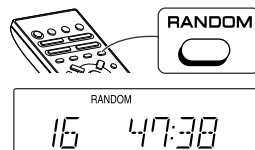

#### To cancel random play:

Press the RANDOM button again. "RANDOM" will go out.

#### Notes:

- The random play will stop automatically when all tracks are played once. (The same track will not be played back twice.)
- In random play, the CD player will select and play tracks automatically. (You cannot select the order of the tracks.)
- If you press the ►► button during random play, you can move to the track selected next by the random operation. On the other hand, the ◀◀ button does not allow you to move to the previous track. The beginning of the track being played will be located.

### ■ Repeat play

All tracks or a programmed sequence can be continuously repeated.

#### To repeat all tracks:

Press the REPEAT button.



#### To repeat a desired track:

Perform steps 1 - 4 in the "Programmed play" section on page 16 and then press the REPEAT button.

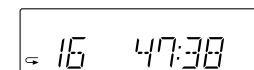

#### To repeat random play:

Press the REPEAT button during random play.

#### To cancel repeat play:

Press the REPEAT button again. "◀" will go out.

#### Caution:

After performing repeat play, be sure to press the ■ button. Otherwise, the disc will play continuously.

## Programmed play

XL-35W

You can choose up to 20 selections for playback in the order you like.

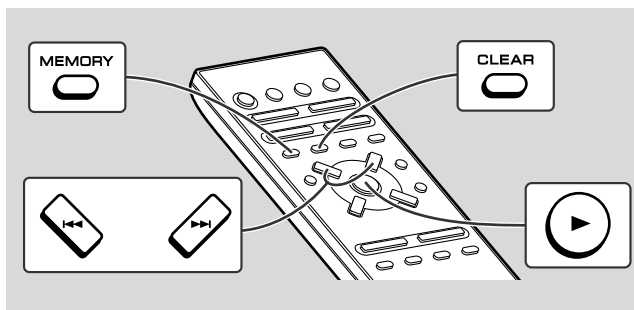

- 1 Whilst in the stop mode, press the **MEMORY (MEMORY/SET)** button to enter the programming save mode.



- 2 Within 30 seconds, press the **◀◀** or **▶▶** button to select the desired track.

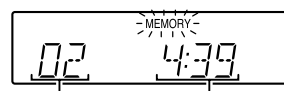

Selected track number      Playback time

- 3 Press the **MEMORY (MEMORY/SET)** button to save the track number.

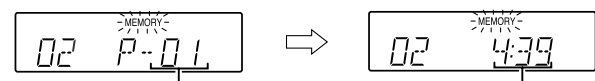

Playback order

Total playback time

- 4 Repeat steps 2 - 3 for other tracks. Up to 20 tracks can be programmed.

- 5 Press the **▶ (▶||)** button to start playback.

### To clear the programmed selections:

Press the **CLEAR** button whilst the "MEMORY" indicator is flashing. Each time the button is pressed, one track will be cleared, beginning with the last track programmed.

### To cancel the programmed play mode:

Whilst in the stop mode and the "MEMORY" indicator is lit, press the **CLEAR** button. The "MEMORY" indicator will disappear and all the programmed contents will be cleared.

### Adding tracks to the programme:

If a programme has been previously stored, the "MEMORY" indicator will be displayed. Then follow steps 1 - 3 to add tracks. The new tracks will be stored after the last track of the original programme.

### Notes:

- Opening the CD compartment automatically cancels the programmed sequence.
- Even if you press the **ON/STAND-BY** button to enter the stand-by mode or the function is changed from CD to some other function, the programmed selections will not be cleared.
- During programme operation, random play is not possible.

## Listening to the radio

Radio

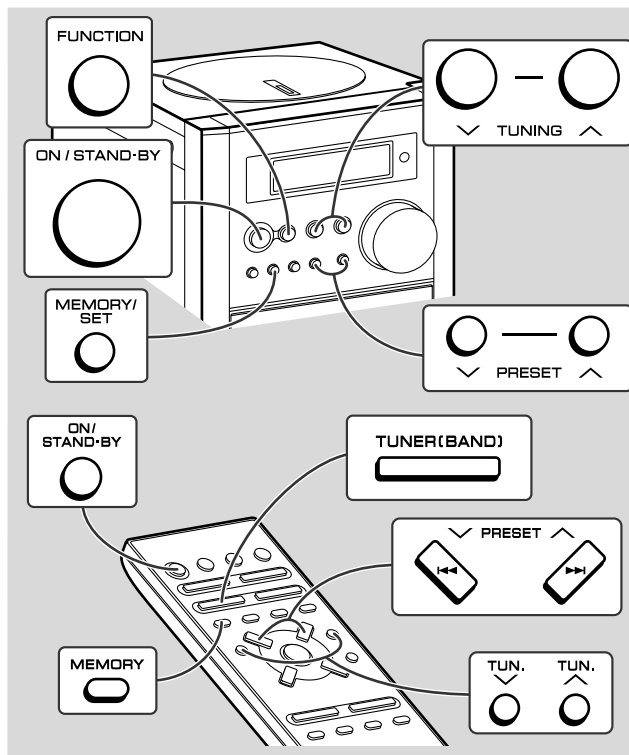

ST FM stereo mode indicator
   
 FM 98.80 MHz FM stereo receiving indicator

**1 Press the ON/STAND-BY button to turn the power on.**

**2 Press the FUNCTION button until "FM" or "AM" appears on the display.**

When operating with the remote control, press the TUNER (BAND) button to select "FM" or "AM".

**3 Press the TUNING (∨ or ∧) button to tune in to the desired station.**

#### Manual tuning:

Press the TUNING button as many times as required to tune in to the desired station.

#### Auto tuning:

When the TUNING button is pressed for more than 0.5 seconds, scanning will start automatically and the tuner will stop at the first receivable broadcast station.

#### Notes:

- This can be operated by pressing the TUN. (∨ or ∧) button on the remote control.
- When radio interference occurs, auto scan tuning may stop automatically at that point.
- Auto scan tuning will skip weak signal stations.
- To stop the auto tuning, press the TUNING button again.

#### To receive an FM stereo transmission:

Press the FUNCTION (TUNER (BAND)) button to display the "ST" indicator.

- "∞" will appear when an FM broadcast is in stereo.
- If the FM reception is weak, press the FUNCTION (TUNER (BAND)) button to extinguish the "ST" indicator. The reception changes to monaural, and the sound becomes clearer.

#### After use:

Press the ON/STAND-BY button to enter the power stand-by mode.



#### Note:

This product can receive FM stereo/FM monaural and AM monaural broadcasts. AM stereo broadcasts will not be played in stereo.

# Listening to memorised stations

## ■ Memorising a station

You can store 30 AM and FM stations in memory and recall them at the push of a button. (Preset tuning)

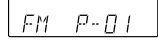
- 1 Perform steps 1 - 3 in "Listening to the radio" on page 17.**
- 2 Press the MEMORY/SET (MEMORY) button to enter the preset tuning saving mode.** 
- 3 Within 5 seconds, press the PRESET (∨ or ∧) button to select the preset channel number.**   
Store the stations in memory, in order, starting with preset channel 1.
- 4 Within 5 seconds, press the MEMORY/SET (MEMORY) button to store that station in memory.**   
If the "MEMORY" and preset number indicators go out before the station is memorised, repeat the operation from step 2.
- 5 Repeat steps 1 - 4 to set other stations, or to change a preset station.**  
When a new station is stored in memory, the station previously memorised will be erased.

**Note:**  
The backup function protects the memorised stations for a few hours should there be a power failure or the AC power lead disconnection.

## ■ To recall a memorised station

Press the PRESET (∨ or ∧) button for less than 0.5 seconds to select the desired station.

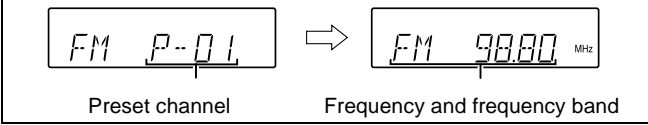

## ■ To scan the preset stations

The stations saved in memory can be scanned automatically. (Preset memory scan)

- 1 Press the PRESET (∨ or ∧) button for more than 0.5 seconds.**  
The preset number will flash and the programmed stations will be tuned in sequentially, for 5 seconds each.
- 2 Press the PRESET (∨ or ∧) button again when the desired station is located.**

## ■ To clear a memorised station

- 1 Recall the memorised station.
- 2 Whilst it is displayed, press the MEMORY/SET (MEMORY) button.
- 3 Within 5 seconds, press the CLEAR button on the remote control.



## Listening to a cassette tape

### Before playback:

- For playback, use normal or low-noise tapes for the best sound. (Metal or CrO<sub>2</sub> tapes are not recommended.)
- Do not use C-120 tapes or poor-quality tapes, as they may cause malfunctions.
- Before loading a tape into the cassette compartment, tighten the slack with a pen or a pencil.



Tape Playback

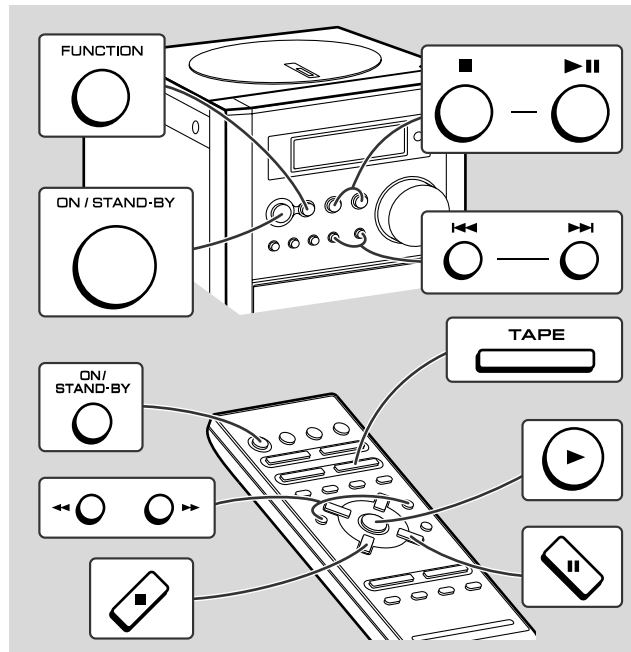

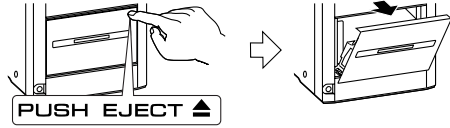
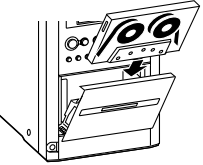
- 1 Press the ON/STAND-BY button to turn the power on.**
- 2 Press the FUNCTION button until "TAPE" appears on the display.**  
When operating with the remote control, press the TAPE button.
- 3 Open the cassette compartment by pushing the area marked "PUSH EJECT ▲".**  

- 4 Load a cassette into the cassette compartment with the side to be played facing toward you.**  

- 5 Close the cassette compartment by pushing the area marked "PUSH EJECT ▲".**
- 6 Press the ►|| button to start playback.**  
When playback is performed using the remote control, press the ► button.

**To stop playback:**

Press the ■ button.

**Fast forward/rewind:**

To advance the tape, press the ►► button on the main unit or the ►► button on the remote control. To rewind it, press the ◀◀ button on the main unit or the ◀◀ button on the remote control.

**Caution:**

- To remove the cassette, press the ■ button, and then open the compartment.
- Before changing from one tape operation to another, press the ■ button.
- If a power failure occurs during tape operation, the tape head will remain engaged with the tape and the cassette compartment will not open. In this case, wait until the power is restored.
- Even if the ►► (II) button is pressed during tape playback, the unit will not enter the pause mode.

## Recording to a cassette tape

### Before recording:

- When recording important selections, make a preliminary test to ensure that the desired material is properly recorded.
- SHARP is not liable for damage or loss of your recording arising from malfunction of this unit.
- The volume and sound controls can be adjusted with no effect on the recorded signal (Variable Sound Monitor).
- **For recording, use only normal tapes. Do not use metal or CrO<sub>2</sub> tapes.**

### Erase-prevention tabs of cassette tapes:

- When recording on a cassette tape, make sure that the erase-prevention tabs are not removed. Cassettes have removable tabs that prevent accidental recording or erasing.
- To protect the recorded sound, remove the tab after recording. Cover the tab hole with the adhesive tape to record on the tape without the tab.

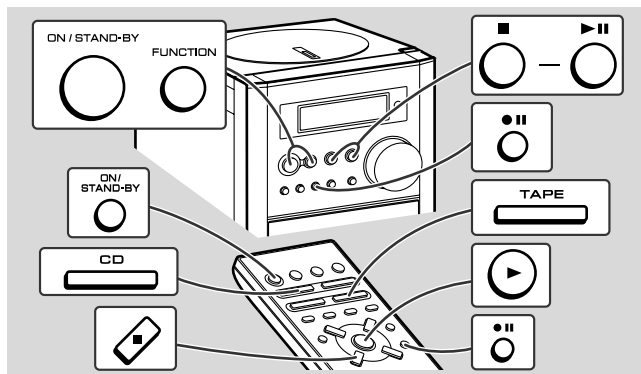
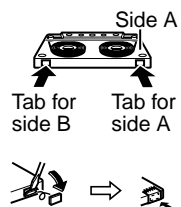

### ■ Recording from a CD

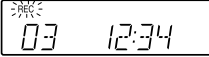
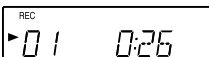
- 1 Press the ON/STAND-BY button to turn the power on.**
- 2 Press the FUNCTION button until "CD STOP" appears on the display.**  
When operating with the remote control, press the CD button.
- 3 Load the desired disc.**
- 4 Load a cassette into the cassette compartment with the side to be recorded on facing you.**  
Wind past the leader of the tape, on which recording cannot be performed.
- 5 Press the [PAUSE] button.**  
  
Recording will be paused.
- 6 Press the [PLAY] button.**  
  
  - CD playback will start in a few seconds after the tape starts.
  - When the playback of the disc is finished, the CD and the cassette will stop automatically.

**To perform programmed recording:**

- 1 Programme tracks (see page 16).
- 2 Press the ●|| button.
- 3 Press the ►|| (►) button.

**To interrupt recording:****Main unit operation:**

Press the ►|| button.

To resume recording, press the ►|| button.

**Remote control operation:**

Press the || button.

To resume recording, press the ► button.

**To stop recording:**

Press the ■ button.

The tape will stop. When the ■ button is pressed again, the CD will stop.

**■ Recording from the radio****1 Tune in to the desired station (see page 17).****2 Load a cassette into the cassette compartment with the side to be recorded on facing you.**

Wind past the leader of the tape, on which recording cannot be performed.

**3 Press the ●|| button.**

Recording will be paused.

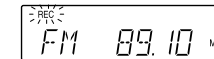
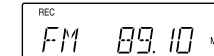
**4 Press the ►|| (►) button.****To stop recording:**

Press the ■ button.

**Notes:**

- If you hear a whistling noise whilst recording an AM station, move the AM loop aerial.
- Whilst recording from the radio, the recording pause function does not work.

**■ Erasing a recorded tape**

1. Load the tape to be erased into the cassette compartment with the side to be erased facing toward you.
2. Press the FUNCTION button until "TAPE" appears on the display.  
When operating with the remote control, press the TAPE button.
3. Press the ●|| button.
4. Press the ►|| (►) button to start erasing.

## Timer and sleep operation

This may be operated only with the remote control.

### Timer playback:

The unit turns on and plays the desired source (CD, tuner, tape) at the preset time.

### Sleep operation:

The radio, compact disc and cassette tape can all be turned off automatically.

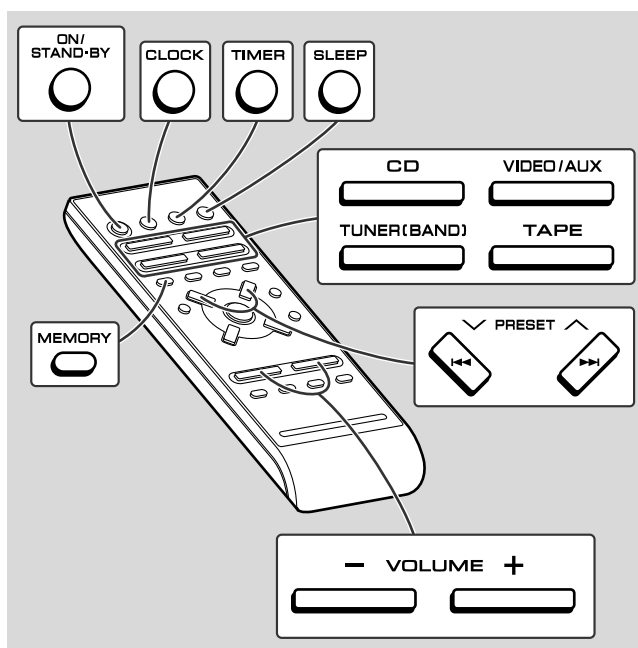

### ■ Timer playback

#### Before setting timer:

- 1 Press the CLOCK button to check that the clock is set to the correct time. (Refer to page 12.)

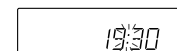

- 2 Load a cassette or disc to be played.



- 1 Press the ON/STAND-BY button to turn the power on.

- 2 Press the CD, TUNER (BAND) or TAPE button to select the desired function.

If you select TUNER (BAND), tune in to the desired station.

- 3 Adjust the volume using the VOLUME buttons.

Do not turn the volume up too high.

- 4 Press the TIMER button and within 6 seconds, press the MEMORY button.

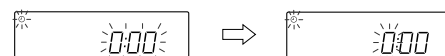

- 5 Within 1 minute, press the PRESET (∨ or ∧) button to specify the hour to start, then press the MEMORY button.

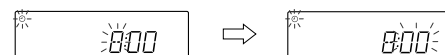

**6** Within 1 minute, press the PRESET (∨ or ∧) button to specify the minutes to start, then press the MEMORY button.

- The timer playback starting time, function, and volume will be displayed, and then the unit will enter the stand-by mode automatically.
- "Ⓜ" will appear and the current time will be displayed.



**To cancel the timer playback:**

Press the ON/STAND-BY button to turn the power on.

**7** When the preset time is reached, playback will start.

The volume will increase gradually until it reaches the volume you were listening to before your system entered the timer stand-by mode.

**8** The unit will enter the stand-by mode one hour after the timer playback starts. However, when CD or tape playback time is one hour or less, it will enter the stand-by mode after completing playback.

**To reset or change the timer setting:**

Perform "Timer playback" from the beginning.

**Note:**

When performing timer playback using another unit connected to the VIDEO/AUX IN sockets, select "VIDEO/AUX" in step 2. At this time, only this unit will be turned on or enter the power stand-by mode automatically. It will enter the power stand-by mode 1 hour after the timer playback starts. (Another unit will not be turned on or off.)

■ **Sleep operation**

**1** Play back the desired sound source.

**2** Press the SLEEP button.

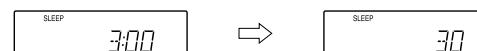

**To change the sleep time:**

Press the SLEEP button repeatedly to select the desired sleep time. The time will decrease as follows.

The amount of sleep time can also be changed whilst in the sleep mode.

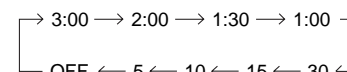

**3** Your system will enter the power stand-by mode automatically after the preset time has elapsed.

The volume will be turned down 1 minute before the sleep operation finishes.

**To cancel the sleep operation:**

Press the ON/STAND-BY button whilst "SLEEP" is indicated.

To cancel the sleep operation without setting the system to the stand-by mode, press the SLEEP button until "OFF" appears on the display.

**To confirm the remaining sleep time:**

Press the SLEEP button once whilst the sleep timer is set.

The remaining sleep time is displayed for about 3 seconds.

## Timer and sleep operation (continued)

### ■ To use timer and sleep operation together

Example: To fall asleep and wake to the same radio station  
You can play back the same source only (the function cannot be switched).

- 1** Set the sleep time (steps 1 - 2, page 24).
- 2** Whilst the sleep timer is set, set the desired playback time (steps 4 - 6, pages 23 - 24).

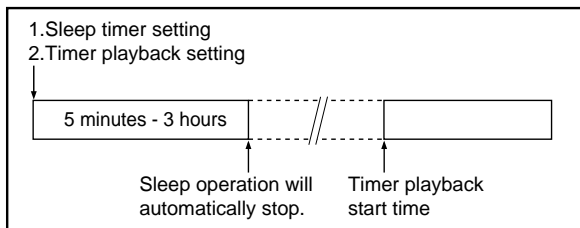

### Caution:

When using the cassette deck, be sure the tape length is long enough to perform both functions. If you want to sleep and wake up listening to a tape, and the length of the tape is shorter than the sleep timer setting, timer playback will not be possible.

## Enhancing your system

The connection lead is not included. Purchase a commercially available lead as shown below.

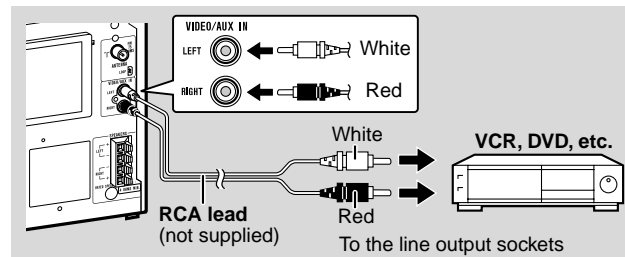

### ■ Listening to the playback sounds from VCR, DVD, etc.

- 1 Use a connection lead to connect the VCR, DVD, etc. to the VIDEO/AUX IN sockets.  
When using video equipment, connect the audio output to this unit and the video output to a television.
- 2 Press the ON/STAND-BY button to turn the power on.
- 3 Press the FUNCTION button until "AUX" appears on the display.  
When operating with the remote control, press the VIDEO/AUX button.
- 4 Play the VCR, DVD, etc.

### Note:

To prevent noise interference, place this unit away from a television.

### ■ To record on a tape from VCR etc.

- 1 Load a cassette into the cassette compartment with the side to be recorded on facing you.
- 2 Press the VIDEO/AUX button.
- 3 Press the ●|| button.
- 4 Press the ►|| (▶) button.
- 5 Play back the VCR etc.

## Troubleshooting chart

XL-35W

Many potential problems can be resolved by the owner without calling a service technician. If something is wrong with this product, check the following before calling your authorised SHARP dealer or service centre.

### ■ General

Symptom	Possible cause
The clock is not set to the correct time.	<ul style="list-style-type: none"> <li>● Did a power failure occur? Reset the clock (refer to page 12).</li> </ul>
When a button is pressed, the unit does not respond.	<ul style="list-style-type: none"> <li>● Set this unit to the power stand-by mode and then turn it back on.</li> <li>● If the unit still malfunctions, reset it. (Refer to page 27.)</li> </ul>
No sound is heard.	<ul style="list-style-type: none"> <li>● Is the volume level set to "MIN"?</li> <li>● Are the headphones connected?</li> <li>● Are the speaker wires disconnected?</li> </ul>

### ■ CD player

Playback does not start.	<ul style="list-style-type: none"> <li>● Is the disc loaded upside down?</li> </ul>
Playback stops in the middle or is not performed properly.	<ul style="list-style-type: none"> <li>● Does the disc satisfy the standards?</li> <li>● Is the disc distorted or scratched?</li> </ul>
Playback sounds are skipped, or stopped in the middle of a track.	<ul style="list-style-type: none"> <li>● Is the unit located near excessive vibrations?</li> <li>● Is the disc very dirty?</li> <li>● Has condensation formed inside the unit?</li> </ul>

### ■ Tuner

The radio makes unusual noises continuously.	<ul style="list-style-type: none"> <li>● Is the unit placed near the TV or computer?</li> <li>● Is the FM or AM aerial placed properly? Move the aerial away from the AC power lead if it's located nearby.</li> </ul>
--	--

### ■ Cassette deck

Cannot record.	<ul style="list-style-type: none"> <li>● Is the erase-prevention tab removed?</li> </ul>
Cannot record tracks with proper sound quality.	<ul style="list-style-type: none"> <li>● Is it a normal tape? (You cannot record on a metal or CrO<sub>2</sub> tape.)</li> </ul>
Cannot erase completely.	
Sound skipping.	<ul style="list-style-type: none"> <li>● Is there any slack in the tape?</li> </ul>
Cannot hear treble.	<ul style="list-style-type: none"> <li>● Is the tape stretched?</li> </ul>
Sound fluctuation.	<ul style="list-style-type: none"> <li>● Are the capstan, pinch roller, or heads dirty?</li> </ul>
Cannot remove the tape.	<ul style="list-style-type: none"> <li>● If a power failure occurs during playback, the heads remain engaged with the tape. Do not open the compartment forcibly. Wait until electricity resumes.</li> </ul>

### ■ Remote control

The remote control does not operate.	<ul style="list-style-type: none"> <li>● Is the AC power lead of the unit plugged in?</li> <li>● Is the battery polarity correct?</li> <li>● Are the batteries dead?</li> <li>● Is the distance or angle incorrect?</li> <li>● Does the remote control sensor receive strong light?</li> </ul>
--------------------------------------	--

### ■ If trouble occurs

When this product is subjected to strong external interference (mechanical shock, excessive static electricity, abnormal supply voltage due to lightning, etc.) or if it is operated incorrectly, it may malfunction.

#### If such a problem occurs, do the following:

- 1 Set the unit to the stand-by mode and turn the power on again.
- 2 If the unit is not restored in the previous operation, unplug and plug in the unit, and then turn the power on.

#### Note:

If neither operation above restores the unit, clear all the memory by resetting it.

### ■ Clearing all the memory (reset)

- 1 Press the ON/STAND-BY button to enter the power stand-by mode.
- 2 Unplug the AC power lead from the AC INPUT socket on the unit.
- 3 Whilst pressing down the MEMORY/SET button and the ■ button, plug the AC power lead into the AC INPUT socket on the unit.

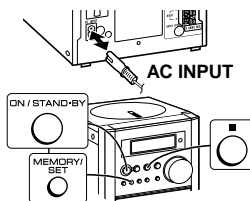

#### Caution:

This operation will erase all data stored in memory including clock, timer settings, tuner preset, and CD programme.

### ■ Condensation

Sudden temperature changes, storage or operation in an extremely humid environment may cause condensation inside the cabinet (CD pickup, tape heads, etc.) or on the transmitter on the remote control. Condensation can cause the unit to malfunction. If this happens, leave the power on with no disc (or cassette) in the unit until normal playback is possible (about 1 hour). Wipe off any condensation on the transmitter with a soft cloth before operating the unit.

## Maintenance

### ■ Cleaning the CD pickup lens

Do not touch the laser pickup lens. If fingerprints or dust accumulate on the pickup, clean it gently with a dry cotton swab.

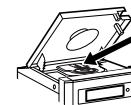

### ■ Cleaning the cabinet

Periodically wipe the cabinet with a soft cloth and a diluted soap solution, then with a dry cloth.

#### Caution:

- Do not use chemicals for cleaning (petrol, paint thinner, etc.). It may damage the cabinet finish.
- Do not apply oil to the inside of the unit. It may cause malfunctions.

### ■ Cleaning the tape-handling parts

- Dirty heads, capstan or pinch roller can cause poor sound and tape jams. Clean these parts with a cotton swab moistened with commercial head/pinch roller cleaner or isopropyl alcohol.
- When cleaning the heads, pinch roller, etc., unplug the unit which contains high voltages.

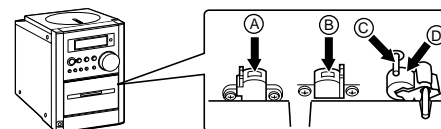

- A Erase head      C Capstan  
B Recording/Playback head      D Pinch roller head

- After long use, the deck's heads and capstan may become magnetised, causing poor sound. Demagnetise these parts once every 30 hours of playing/recording time by using a commercial tape head demagnetiser. Read the demagnetiser's instructions carefully before use.

## Specifications

XL-35W

As part of our policy of continuous improvement, SHARP reserves the right to make design and specification changes for product improvement without prior notice. The performance specification figures indicated are nominal values of production units. There may be some deviations from these values in individual units.

### ■ General

<b>Power source</b>	AC 110, 127, 220, 230 - 240 V, 50/60 Hz
<b>Power consumption</b>	28 W
<b>Dimensions</b>	Width: 160 mm (6-5/16") Height: 240 mm (9-1/2") Depth: 247 mm (9-3/4")
<b>Weight</b>	2.6 kg (5.8 lbs.)

### ■ Amplifier

<b>Output power</b>	MPO: 15 W (7.5 W + 7.5 W) (10 % T.H.D.) RMS: 10 W (5 W + 5 W) (10 % T.H.D.)
<b>Output terminals</b>	Speakers: 4 ohms Headphones: 16 - 50 ohms (recommended: 32 ohms)
<b>Input terminals</b>	Video/Auxiliary (audio signal): 500 mV/47 k ohms

### ■ Tuner

<b>Frequency range</b>	FM: 88 - 108 MHz AM: 531 - 1,602 kHz
------------------------	---

### ■ CD player

<b>Type</b>	Compact disc player
<b>Signal readout</b>	Non-contact, 3-beam semiconductor laser pickup
<b>D/A converter</b>	1-bit D/A converter
<b>Frequency response</b>	20 - 20,000 Hz
<b>Dynamic range</b>	90 dB (1 kHz)

### ■ Cassette deck

<b>Frequency response</b>	50 - 14,000 Hz (normal tape)
<b>Signal/noise ratio</b>	50 dB (recording/playback)
<b>Wow and flutter</b>	0.25 % (WRMS)

### ■ Speaker

<b>Type</b>	10 cm (4") full-range speaker
<b>Maximum input power</b>	10 W
<b>Rated input power</b>	5 W
<b>Impedance</b>	4 ohms
<b>Dimensions</b>	Width: 145 mm (5-3/4") Height: 240 mm (9-1/2") Depth: 175 mm (6-15/16")
<b>Weight</b>	1.4 kg (3.1 lbs.)/each



**MEMO**





**MEMO**



**SHARP**  
SHARP CORPORATION

TINSE0121SJZZ  
02L N HK ①